

**POULTRY PROCESSING SOLUTIONS  
POWERED BY INTEGRATION EXPERTISE**



**DURAVANT**



## DURAVANT'S INTEGRATED LINE FOR POULTRY PROCESSING

Duravant's Family of operating companies offer comprehensive equipment portfolios that help span the entire poultry processing line – from cut-up to deboning and portioning to inspection, seasoning, cooking and packaging. Delivering state-of-the-art technology and seamless integration with single source responsibility, Duravant helps processors ensure food safety, boost production efficiency and maximize yield while minimizing labor requirements.

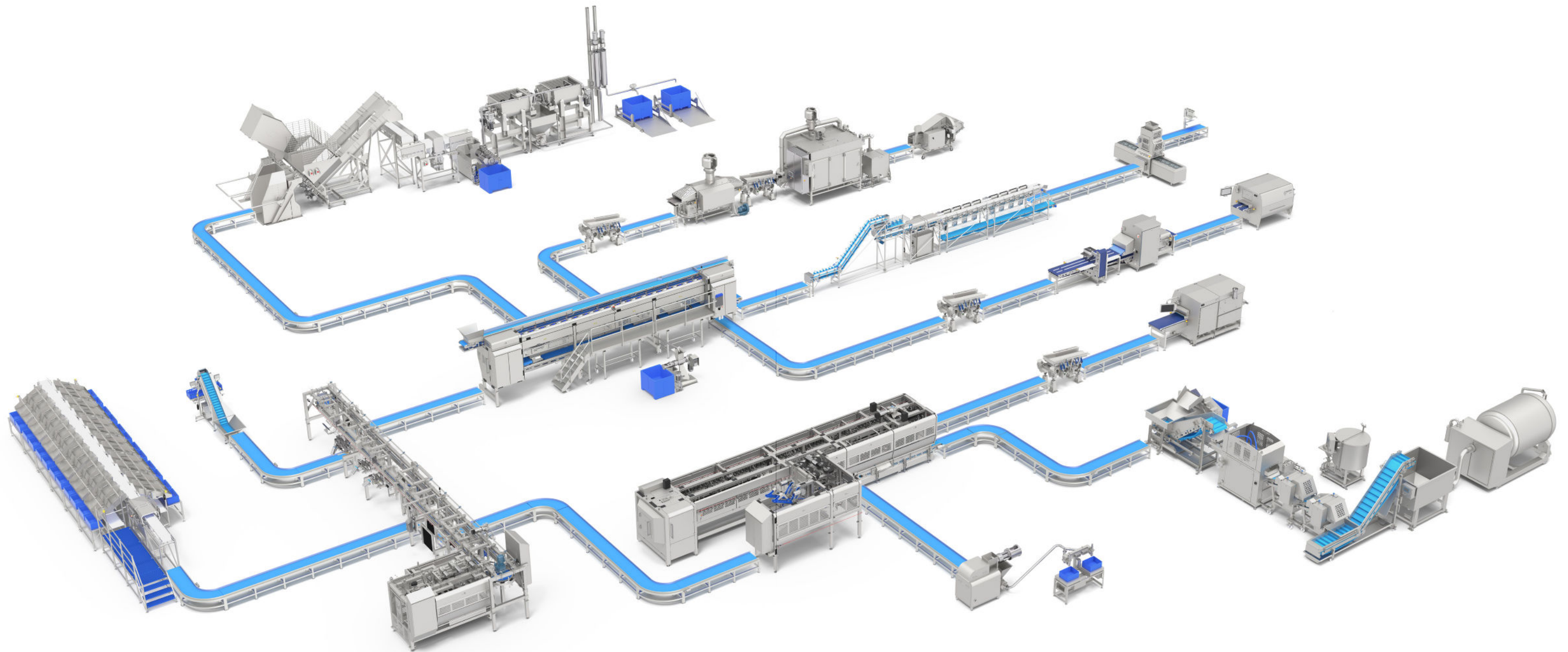

# WHOLE CHICKEN PROCESSING

Solutions to meet the widest range of product specifications and cutting requirements, meeting the highest standards set by retailers, fast food companies and institutional organizations from around the world.

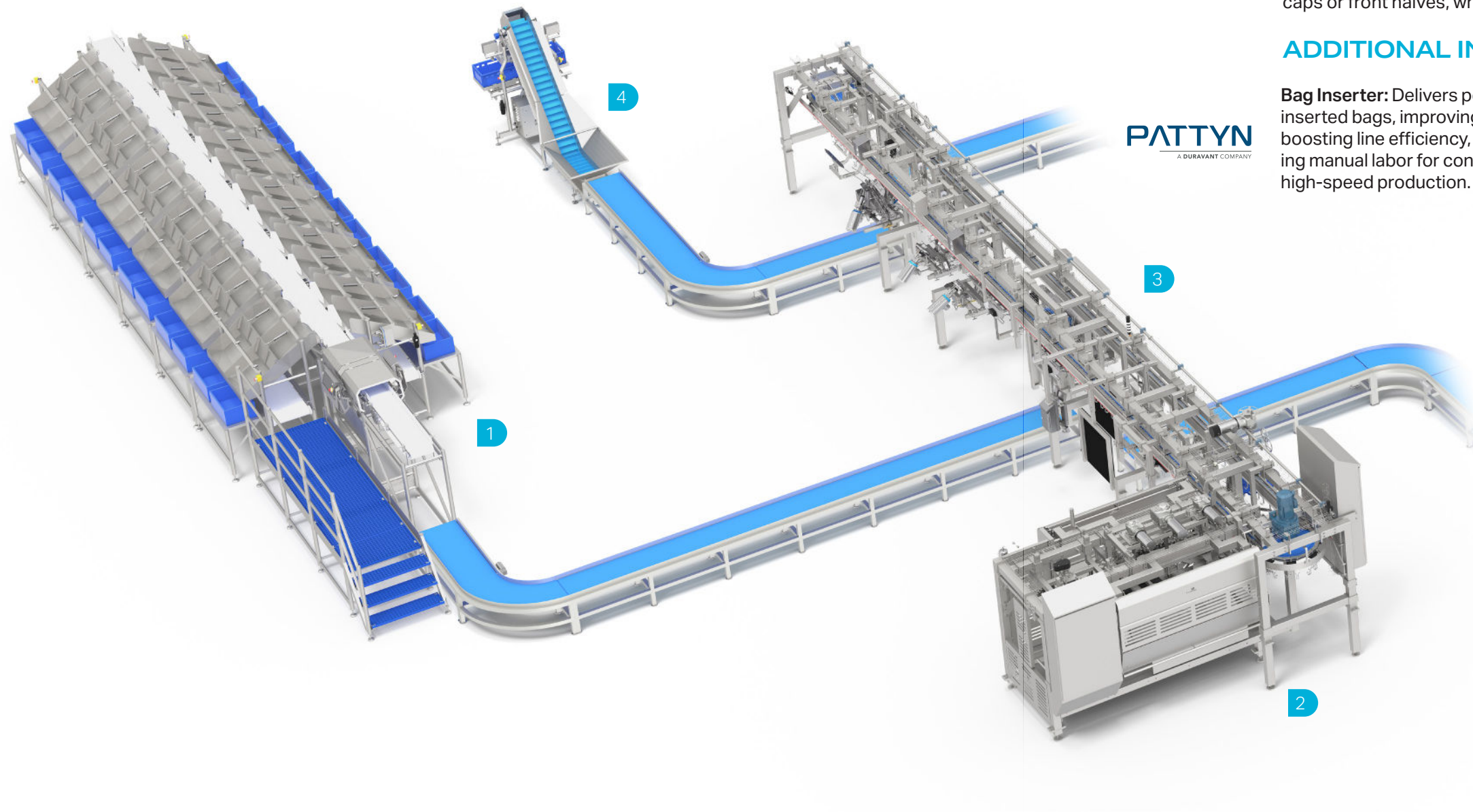

**1 Whole Bird Grader:** Features ergonomic or automatic infeed systems for loading whole birds, offering fast, accurate, and gentle grading of fresh or bagged birds into carton boxes, tubs, crates, or other containers.



**2 Whole Chicken Rehanger:** Efficiently and automatically transfers whole chickens from one secondary processing line to another with a capacity up to 15,000 bph, while maintaining proper orientation.

**3 Cut-Up Line:** An advanced poultry processing system designed to efficiently, flexibly and precisely cut chickens with a speed up to 7,200bph into various parts like for example: Whole wings, wing segments, breast caps or front halves, whole legs, thighs and drumsticks.

## ADDITIONAL INTEGRATED LINE SOLUTIONS



**Bag Inserter:** Delivers perfectly inserted bags, improving hygiene, boosting line efficiency, and reducing manual labor for consistent, high-speed production.

**Hermetic Bag Sealer:** Provides airtight, contamination-free seals with integrated vacuum and gas flush technology – enhancing food safety, extending shelf life, and ensuring reliable packaging integrity in high-volume production.



## CHICKEN WINGS



**3 Wing Cutter Modules:** Cuts the wings anatomically from the chicken with optimal yield, while ensuring high cutting accuracy. Optional whole wings, drumettes, flats and tips.



**4 Batch Weigher:** Effortlessly transforms continuous product flow into target weight batches, ideal for fresh, frozen, large, small, or non-sticky products, dropped into bags, crates, or cartons.

# CHICKEN BREAST PROCESSING

Solutions that bring a combination of durable mechanics and cutting-edge technology in automation ensuring the highest possible yields.



**1 White Meat Deboner:** Advanced white meat deboning system offers high-speed processing at 6,000 bph in a compact 12 x 2.5m footprint. It produces versatile outputs including butterfly fillets, half fillets, and tenders, while featuring integrated components such as a skinner, wishbone remover and fillet harvester. User-friendly touch-screen controls. With a flexible conveyor system, this technology represents a significant advancement in breast deboning, combining efficiency, safety, and adaptability for modern poultry processing needs.



**2 Custom Grader:** Tailored systems with customized infeed, dynamic weighing for precision, and flexible sorting options. Fully customizable sorting stations with batching, labeling, and optional takeaway conveyors. MATRIX software integration ensures complete traceability in the production line.

**3 Automatic Tray Filling:** Seamlessly delivers the batches produced by a grading system to a packing machine.



**4 Control & Distribution Solution:** Advanced grading, sorting and distribution system. Uses camera-based technology and AI to automatically recognize and sort packaged chicken products before tray wrapping. Recognition for tray size, color, product type, quantity, and orientation. Improve labor management, reduce waste and increase efficiency in the final packaging and distribution.



**5 Separator & Meat Pump:** Compact separator for small volume, high value ground applications such as breast trim. And low volume custom meat pump designed to deliver the finished ground or mechanically separated product to the desired location.



## ADDITIONAL INTEGRATED LINE SOLUTIONS

**Alignment Conveyor:** Precisely aligns and singulates products to maximize downstream equipment efficiency through customized, application-specific design.



**Trim Line:** An intelligent trimming system that tracks yield, capacity, and trim quality per operator. Real-time data throughout production enables quick adjustments and maximizes profitability.



**Tumbler:** User-friendly vacuum tumblers that ensure perfectly flavored, consistently marinated products with every use, built for durability and handling both gentle and intensive mixing for optimal results.

**Injector:** Innovative design that features individually controlled needles, ensuring consistent injection even around bones.



**Flame Grill:** Premium searing, roasting and grilling of value-added poultry for authentic taste while maximizing product quality and consistency.

**Spiral Oven:** Continuous cooking with the most flexibility; for maximum product uniformity and cost-efficiency.

# WHOLE LEG PROCESSING



Solutions that can accommodate a variety of bird sizes and produce final products that meet the highest standards.

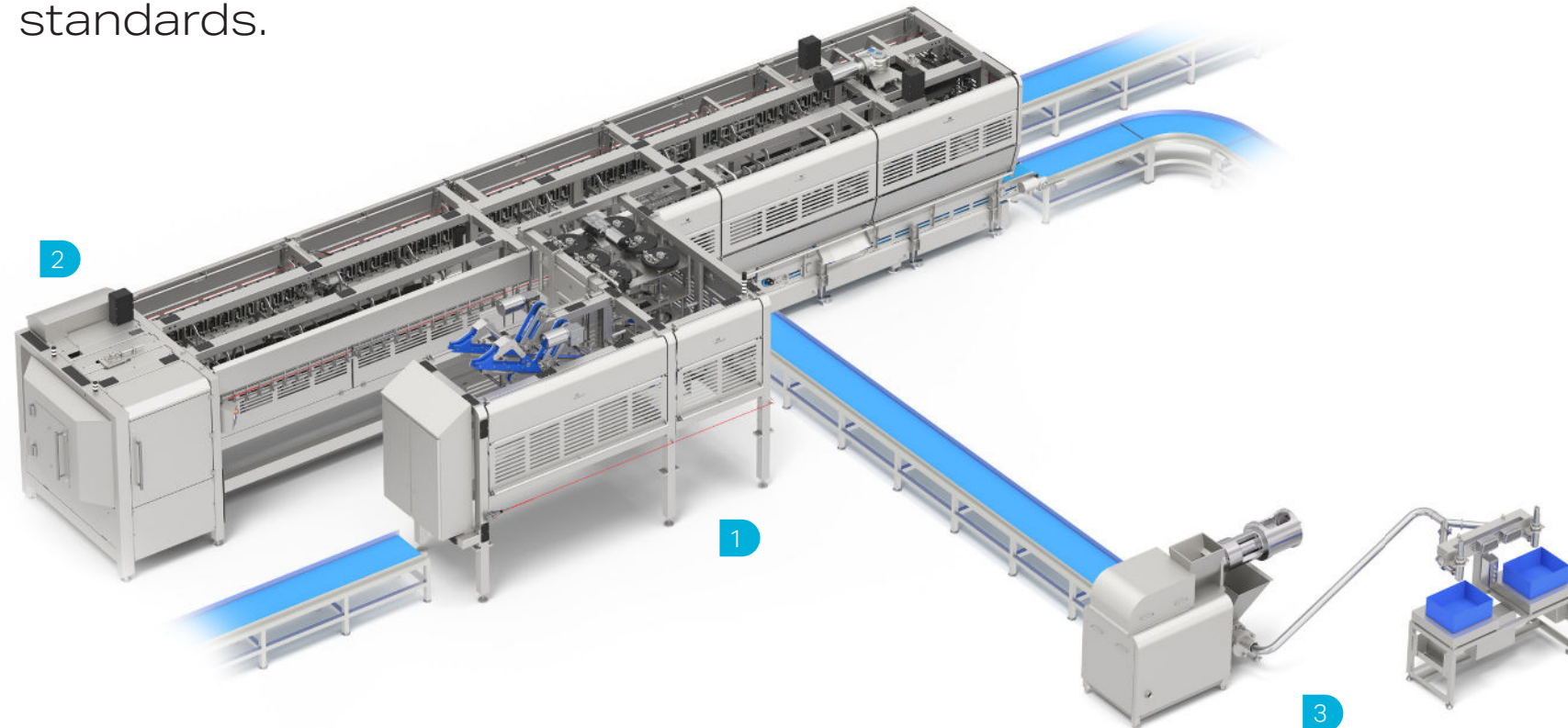

**1 Automatic Leg Transfer System (ALTS):** Automates chicken leg transfer from cut-up to deboning, handling 14,400 legs/hour, accommodating both legs, integrating with software, and enhances efficiency by eliminating manual handling, ensuring precise orientation, and maintaining product quality throughout the transfer process.

**2 Thigh Deboner:** The OPTiX is an intelligent deboning solution that processes whole chicken legs using advanced X-Ray technology to detect the kneecap and bone length, ensuring maximum yield. It precisely debones the thigh and cuts the drumstick in a way that guarantees a perfect presentation, delivering consistent quality for premium product appearance.

**3 Separator:** Mid-range capacity POSS separator for ground dark meat with custom pumping and dual boxfilling station.



## ADDITIONAL INTEGRATED LINE SOLUTIONS



**Transfer Conveyor:** Safe, efficient transfer of fresh and frozen poultry products through a hygienic design available in smooth or rigidized stainless steel construction for optimal food safety and cleanability.

**Distribution Conveyor:** Customized to fit packaging distribution lines. Includes stainless steel pneumatic gates and control systems. Available with upward vibration or horizontal motion for gentle transfer.



**Flame Grill:** Premium searing, roasting and grilling of value-added meat for authentic taste while maximizing product quality and consistency.

**Spiral Oven:** Continuous cooking with the most flexibility; for maximum product uniformity and cost-efficiency.



**Bag Inserter:** Delivers perfectly inserted bags, improving hygiene, boosting line efficiency, and reducing manual labor for consistent, high-speed production.

**Hermetic Bag Sealer:** Provides airtight, contamination-free seals with integrated vacuum and gas flush technology – enhancing food safety, extending shelf life, and ensuring reliable packaging integrity in high-volume production.



## TENDERS



**4 Alignment Conveyor:** Precisely aligns and singulates products to maximize downstream equipment efficiency through customized, application-specific design.

**Scale Feed Conveyor:** Delivers instant product control and consistent flow to weighing systems, available with upward vibration or horizontal motion for gentle transfer.



**5 X-Ray Vision:** Designed to detect foreign objects in unpacked, low-profile protein products using advanced Ultra High-Definition X-ray technology, capable of identifying even the smallest bone fragments.

**6 Dual Lane Portion Cutter:** a dual-lane, fixed-weight portion cutter that uses a top camera on each lane to scan the volume of the chicken fillet, tender fillets, or deboned leg meat. It is typically used for portioning poultry cubes, poultry slices, karagee, kakugiri or BLK.

# THIGH & DRUMSTICK PROCESSING

Solutions that can accommodate a variety of bird sizes and produce final products that meet the highest standards.

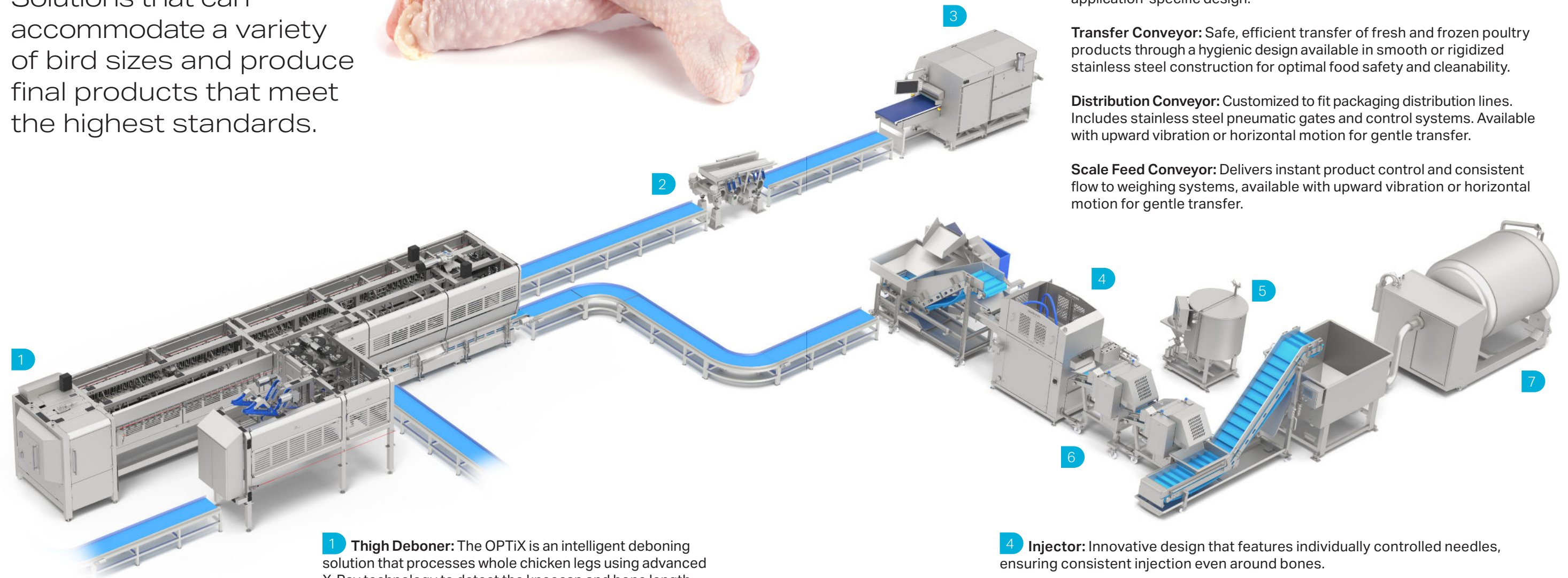

**1 Thigh Deboner:** The OPTiX is an intelligent deboning solution that processes whole chicken legs using advanced X-Ray technology to detect the kneecap and bone length, ensuring maximum yield. It precisely debones the thigh and cuts the drumstick in a way that guarantees a perfect presentation, delivering consistent quality for premium product appearance.



**3 Waterjet Cutter:** designed to maximize yields when cutting poultry fillets or deboned leg meat into fixed-weight portions. Using a camera and laser for precise scanning, it calculates the optimal cutting pattern. It's ideal for portioning fillets into fixed-weight pieces, cubes, or strips, and trimming leg meat into steaks or patties.



**2 Alignment Conveyor:** Precisely aligns and singulates products to maximize downstream equipment efficiency through customized, application-specific design.

**Transfer Conveyor:** Safe, efficient transfer of fresh and frozen poultry products through a hygienic design available in smooth or rigidized stainless steel construction for optimal food safety and cleanability.

**Distribution Conveyor:** Customized to fit packaging distribution lines. Includes stainless steel pneumatic gates and control systems. Available with upward vibration or horizontal motion for gentle transfer.

**Scale Feed Conveyor:** Delivers instant product control and consistent flow to weighing systems, available with upward vibration or horizontal motion for gentle transfer.



**4 Injector:** Innovative design that features individually controlled needles, ensuring consistent injection even around bones.

**5 Brine Mixer:** High-performance Venturi system ensures smooth, lump-free mixing and offers optional double-jacket cooling for consistent product quality.

**6 Tenderizer:** Elevates product quality through better protein activation, higher water uptake, and superior tenderness, all while cutting grill and cooking loss.

**7 Tumbler:** User-friendly vacuum tumblers that ensure perfectly flavored, consistently marinated products with every use, built for durability and handling both gentle and intensive mixing for optimal results.

## ADDITIONAL INTEGRATED LINE SOLUTIONS

**Flame Grill:** Premium searing, roasting and grilling of value-added poultry for authentic taste while maximizing product quality and consistency.

**Spiral Oven:** Continuous cooking with the most flexibility; for maximum product uniformity and cost-efficiency.



# MECHANICALLY DEBONED MEAT PROCESSING

Solutions that mechanically separate all poultry cuts from Cut-Up, Dark & White meat deboning equipment products.

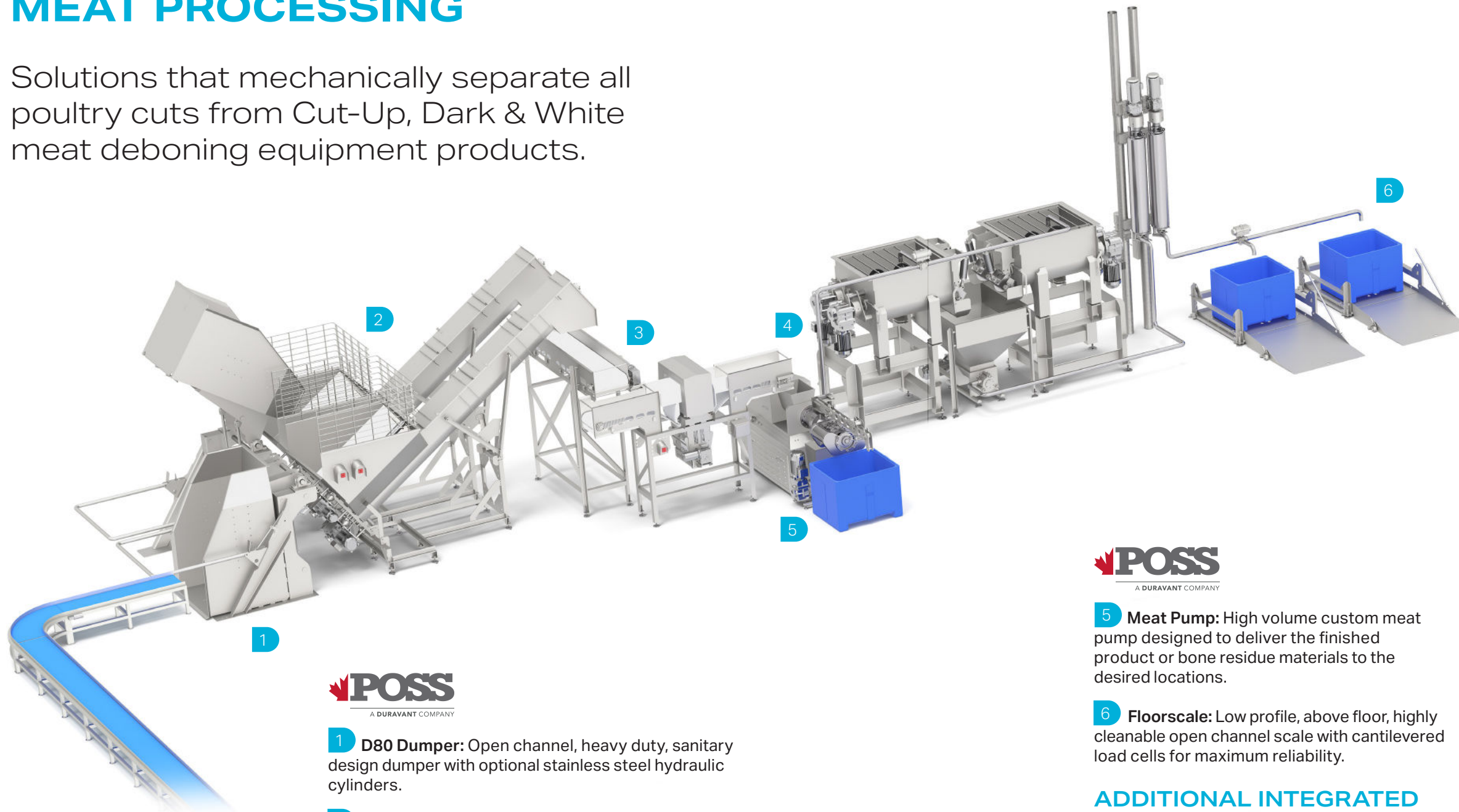

**1 D80 Dumper:** Open channel, heavy duty, sanitary design dumper with optional stainless steel hydraulic cylinders.

**2 Screw Conveyor:** Open channel, heavy duty, sanitary design transfer screw conveyor with surge hopper and available agitator.

**3 Cross Conveyor:** Customizable, sanitary design, reversible, metal free zone available conveyors.

**4 Separator:** Highest yielding, heavy duty meat bone separator designed for all poultry input materials with highest reliability and lowest costs of ownership.



**5 Meat Pump:** High volume custom meat pump designed to deliver the finished product or bone residue materials to the desired locations.

**6 Floorscale:** Low profile, above floor, highly cleanable open channel scale with cantilevered load cells for maximum reliability.

## ADDITIONAL INTEGRATED LINE SOLUTIONS



**White Meat Deboner:** After deboning of the breast caps or front halves, the carcass will be distributed to the POSS meat separator system for mechanically deboned meat.



## GROUND CHICKEN



**Separator:** Separator for various volumes of ground applications such as breast trim. Can be configured for mechanically separated products.

**Meat Pump:** Custom meat pump designed to deliver the finished ground or mechanically separated product to the desired location.

**Dual Box fill:** Fully Sanitary, alternating box filling station with highly consistent filling of finished ground or mechanically separated meat into boxes or bags with integrated line control available.



## COOKED AND/OR DICED CHICKEN PROCESSING

Premium solutions that provide the highest consistency, accuracy and product integrity no matter the end product.

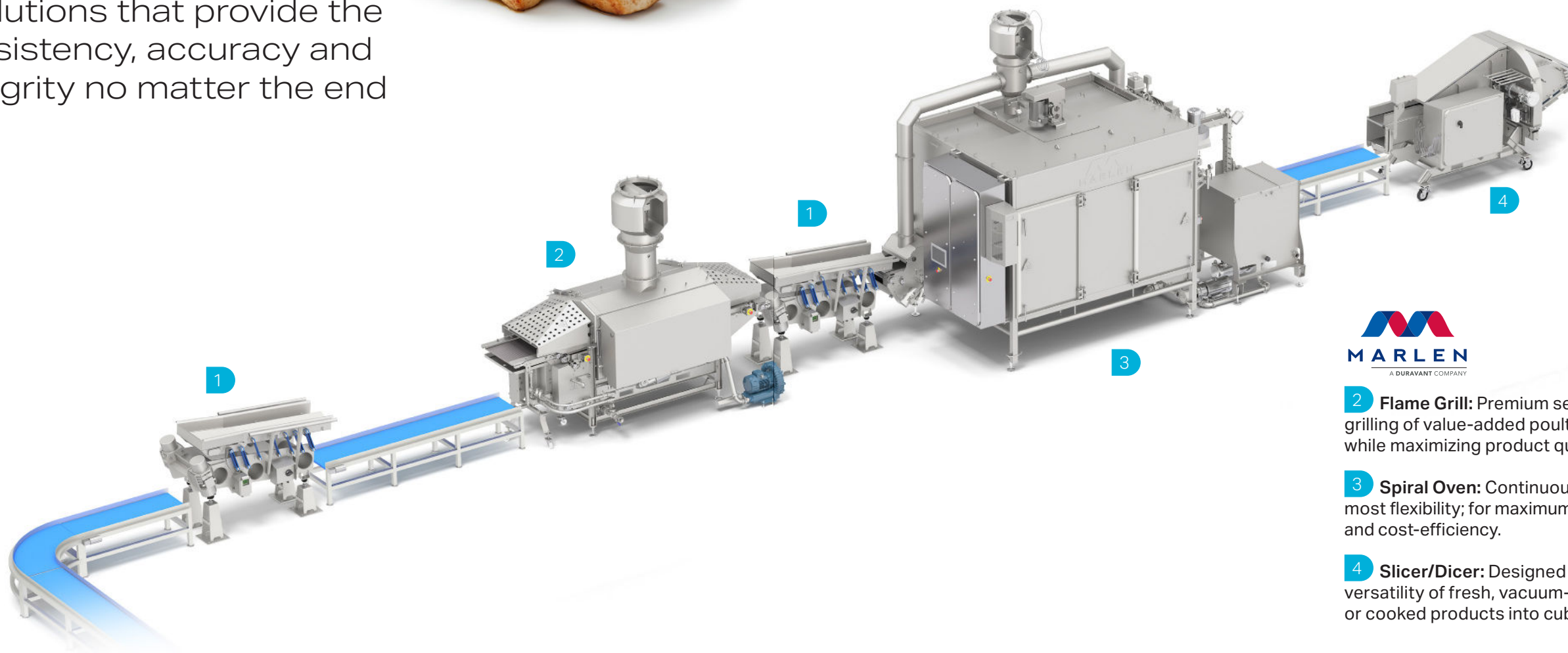

**1 Transfer Conveyor:** Safe, efficient transfer of fresh and frozen poultry products through a hygienic design available in smooth or rigidized stainless steel construction for optimal food safety and cleanability.

**VERYX and COMPASS Optical Sorters:** Delivers superior quality control of processed proteins by detecting and removing defects and foreign materials, enhancing yield, reducing labor and ensuring safety.

**Distribution Conveyor:** Customized to fit packaging distribution lines. Includes stainless steel pneumatic gates and control systems. Available with upward vibration or horizontal motion for gentle transfer.

**Scale Feed Conveyor:** Delivers instant product control and consistent flow to weighing systems, available with upward vibration or horizontal motion for gentle transfer.

**Grading Conveyor:** Features stainless steel screens in a variety of styles to align, separate, dewater, length grade, scalp, fines removal, customized size for line flow capacity.



**2 Flame Grill:** Premium searing, roasting and grilling of value-added poultry for authentic taste while maximizing product quality and consistency.

**3 Spiral Oven:** Continuous cooking with the most flexibility; for maximum product uniformity and cost-efficiency.

**4 Slicer/Dicer:** Designed for complete cutting versatility of fresh, vacuum-tumbled, crust-frozen or cooked products into cubes or strips.

# DIGITAL SOLUTIONS

## Intelligent Integration

At Duravant, we offer digital solutions that connect your equipment and process. Duravant Lifecycle Services enhances access to our parent company's leadership in digitization and IIoT technologies to help you stay competitive, now and in the future.

## CHICKSORT

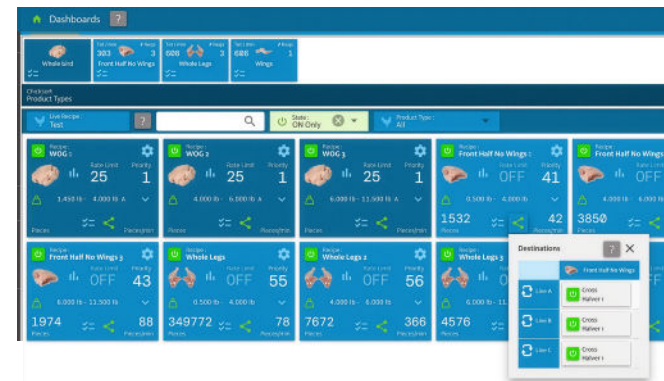

- Intelligent control
- Distribution & cut up
- Quality grading
- Sizing
- X-ray analysis



**MATRIX**

- Sales Orders
- Labelling
- Palletizing
- Inventory
- Traceability
- Yield Analysis

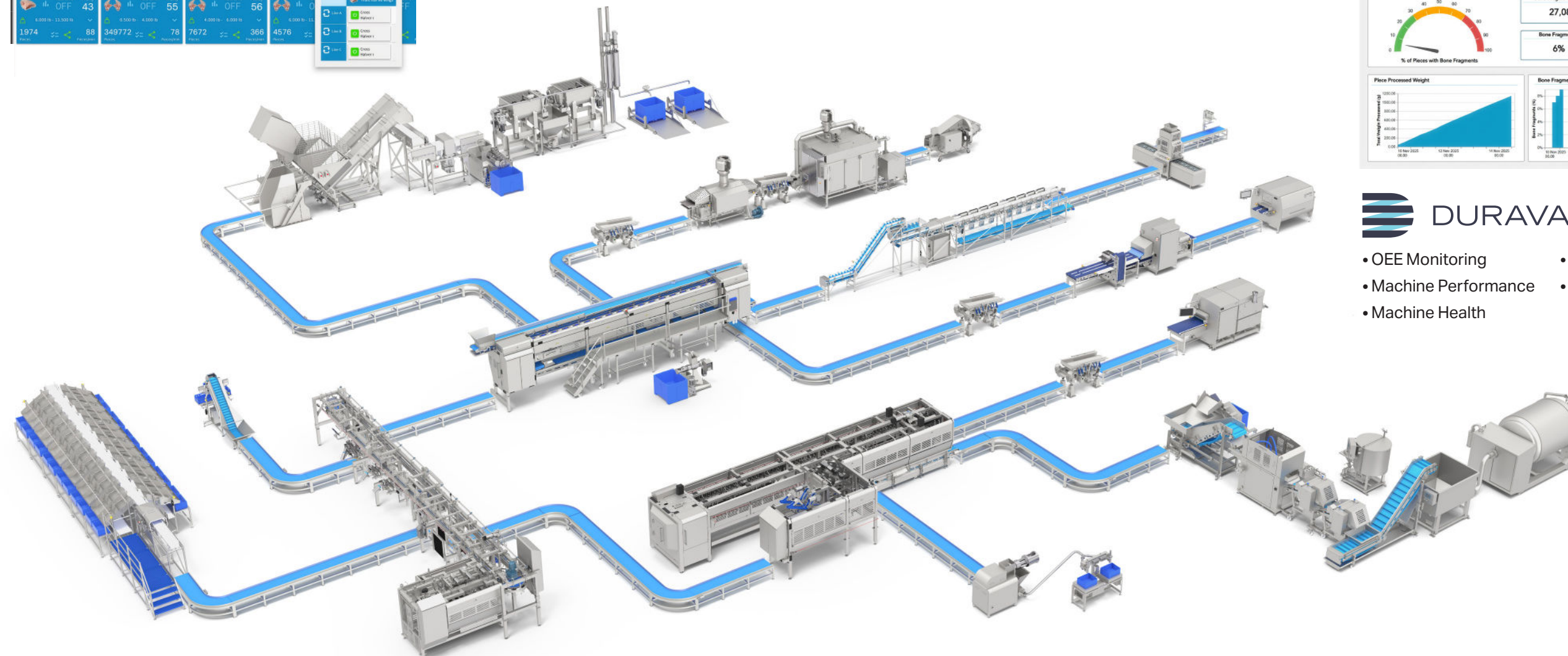

**DURAVANT ONSIGHT**



- OEE Monitoring
- Machine Performance
- Machine Health
- Product Quality
- Maintenance

# DURAVANT LIFECYCLE SERVICES



Building Partnerships, Maximizing Value.

Duravant Lifecycle Services is the power behind our aftermarket solutions for Duravant's portfolio of food processing, packaging and material handling equipment. We bring a consultative approach to help you optimize the performance of your equipment throughout its entire service life. Our goal is to deliver service solutions that reduce operational disruptions and costs, optimize safety and quality, and improve the overall equipment effectiveness within your operation.

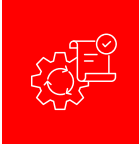
## SERVICES

	FIELD SERVICES		TECHNICAL SUPPORT		PREVENTIVE MAINTENANCE
	INSTALLATION & COMMISSIONING		APPLICATIONS SUPPORT		PRE-OWNED EQUIPMENT REGISTRATION

## PRODUCTIVITY

	TRAINING		SERVICE PLANS		PRODUCTIVITY PROGRAMS
	CUSTOMER CARE		UPGRADE & RETROFITS		PROJECT MANAGEMENT

## PARTS AND REPAIRS

	SPARE PARTS		ACCESSORIES & CONSUMABLES		REPAIR & REFURBISHMENT		PARTS KITS
---	-------------	---	---------------------------	---	------------------------	--	------------



**KEEPING GOODNESS IN MOTION**

**WE ARE DURAVANT**

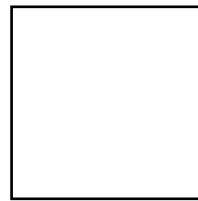

**[DURAVANT.COM](https://www.duravant.com)**



**TELEPHONE USA 844.DURAVANT**  
**TELEPHONE GLOBAL 1.630.635.3910**