

**MEAT PROCESSING SOLUTIONS  
POWERED BY INTEGRATION EXPERTISE**



**DURAVANT**



## Duravant's Integrated Lines for Meat Processing

Duravant's Family of operating companies offer comprehensive equipment portfolios that help span the multiple meat processing lines from trimming to separating to seasoning, cooking and packaging. Delivering state-of-the-art technology and seamless integration with single source responsibility, Duravant helps processors ensure food safety, boost production efficiency and maximize yield while minimizing labor requirements.

Whole Muscle

Beef Jerky

Brisket

Pork Loin

Ham

Advanced Meat Recovery

Hamburger

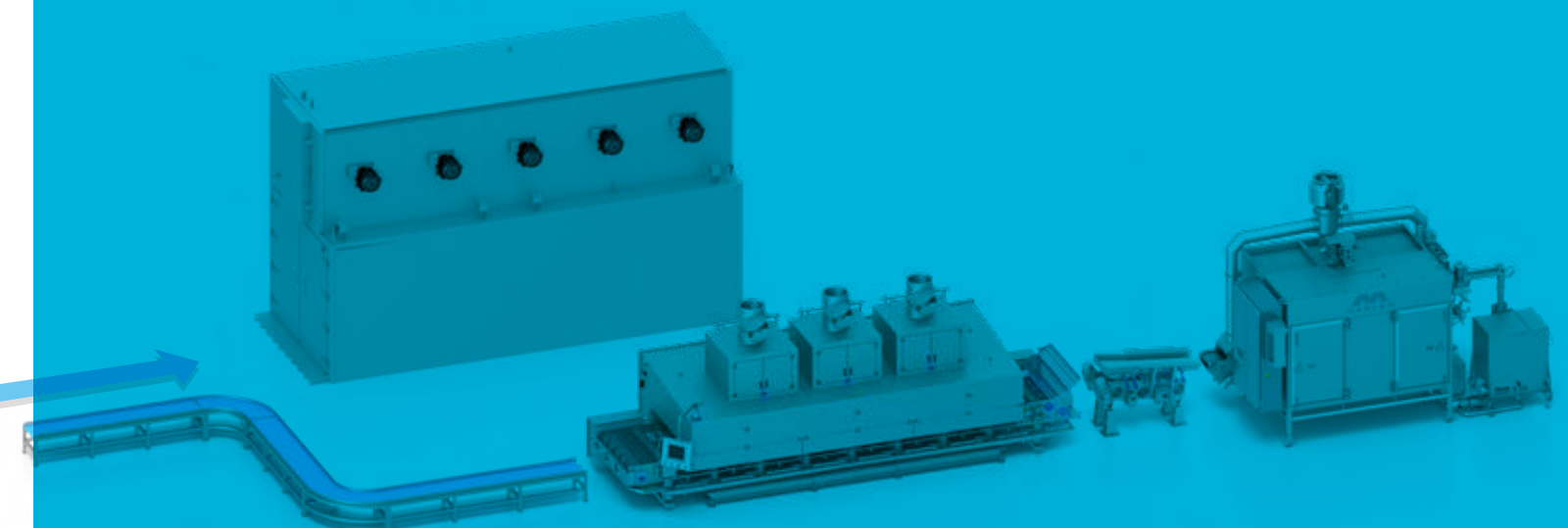
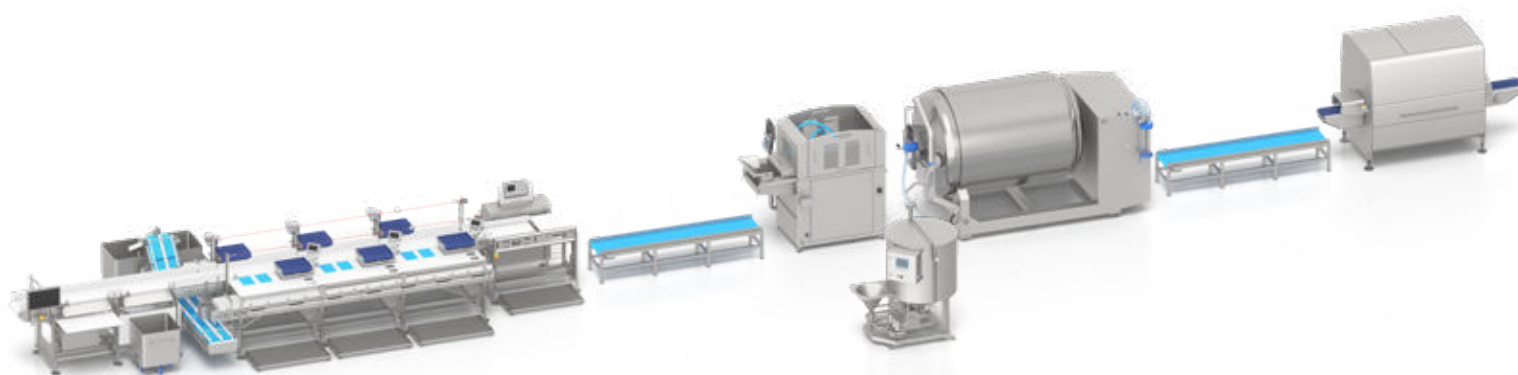

**HENNEKEN**  
A DURAVANT COMPANY

**KEY**  
TECHNOLOGY  
A DURAVANT COMPANY

**marelec**  
A DURAVANT COMPANY

**MARLEN**  
A DURAVANT COMPANY

**NVENIA**  
A DURAVANT COMPANY

**PATTYN**  
A DURAVANT COMPANY

**POSS**  
A DURAVANT COMPANY

# WHOLE MUSCLE

Solutions built with durable, reliable equipment to support every stage of whole muscle production, delivering consistent performance and the highest standards of quality.

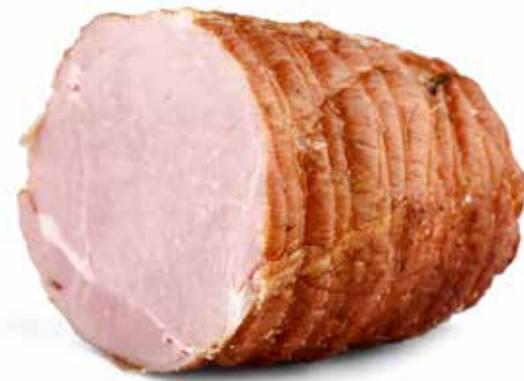

**1 Injector:** Innovative design that features individually controlled needles, ensuring consistent injection even around bones.

**2 Tumbler:** User-friendly vacuum tumblers that ensure perfectly flavored, consistently marinated products with every use, built for durability and handling both gentle and intensive mixing for optimal results.



**3 Vacuum Pump:** Engineered for gentle handling and optimal vacuumization, ensuring superior particle definition, product integrity, and precise portioning across high-volume meat applications.

**4 Smokehouse:** Built for precise control and uniform results, delivering consistent flavor, color, and texture with flexible, automated performance across diverse applications.

**5 Blast Chill Cell:** Solutions that rapidly chill products with precise airflow and temperature control, ensuring food safety, extended shelf life, and consistent quality across high-volume operations.

## ADDITIONAL INTEGRATED LINE SOLUTIONS

**Bag Inserting:** Engineered to deliver perfectly formed and hygienically inserted bags with high-speed precision, supporting food safety, shelf-life protection, and efficient case-ready protein packaging for demanding production environments.

**Bag Sealing:** Designed to deliver airtight, contamination-preventing seals that enhance product freshness, extend shelf life, and ensure secure, leak-free protein packaging in high-throughput environments.

**Tenderizer:** Elevates product quality through better protein activation, higher water uptake, and superior tenderness, all while cutting grill and cooking loss.



# BEEF JERKY

Solutions designed to deliver consistent results, production run after production run, at any volume—ensuring quality and reliability every time.



**1 Trim line:** An intelligent trimming system that tracks yield, capacity, and trim quality per operator. Real-time data throughout production enables quick adjustments and maximizes profitability.

**2 Injector:** Innovative design that features individually controlled needles, ensuring consistent injection even around bones.



**3 Tumbler:** User-friendly vacuum tumblers that ensure perfectly flavored, consistently marinated products with every use, built for durability and handling both gentle and intensive mixing for optimal results.



**4 Slicer/Dicer:** Designed for complete cutting versatility of fresh, vacuum-tumbled, crust-frozen or cooked products into cubes or strips.

**5 Batch Dehydrator:** Solutions that deliver uniform drying with precise airflow and temperature control, ensuring consistent moisture removal, product integrity, and efficiency across high-volume applications.

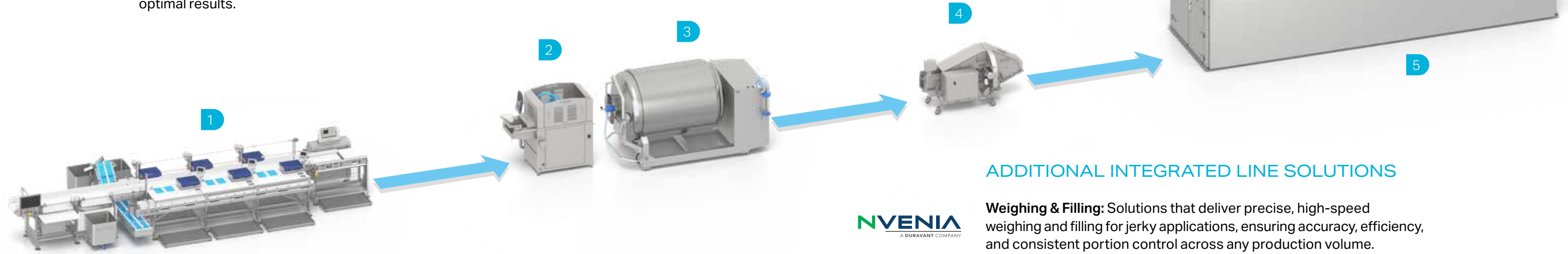

## ADDITIONAL INTEGRATED LINE SOLUTIONS



**Weighing & Filling:** Solutions that deliver precise, high-speed weighing and filling for jerky applications, ensuring accuracy, efficiency, and consistent portion control across any production volume.



**Optical Sorters:** Delivers superior quality control of processed proteins by detecting and removing defects and foreign materials, enhancing yield, reducing labor and ensuring safety.

# BRISKET

Solutions engineered for scalable, efficient operations that get brisket right every time—delivering accuracy and quality at any production level.



**1 Trim line:** An intelligent trimming system that tracks yield, capacity, and trim quality per operator. Real-time data throughout production enables quick adjustments and maximizes profitability.



**7 Portio:** a versatile portion cutter designed to create consistent, natural-looking portions. It uses advanced camera technology and adjustable cutting angles to improve product appearance and accuracy. Its smooth infeed system helps handle larger pieces efficiently, making it ideal for various types of protein processing.

**2 Injector:** Innovative design that features individually controlled needles, ensuring consistent injection even around bones.



**3 Tumbler:** User-friendly vacuum tumblers that ensure perfectly flavored, consistently marinated products with every use, built for durability and handling both gentle and intensive mixing for optimal results.

**4 Slicer/Dicer:** Designed for complete cutting versatility of fresh, vacuum-tumbled, crust-frozen or cooked products into cubes or strips.



**5 Batch Oven:** Designed for precise, repeatable cooking with flexible configurations, ensuring consistent results, product integrity, and efficiency across a variety of applications.

**6 Blast Chill Cell:** Solutions that rapidly chill products with precise airflow and temperature control, ensuring food safety, extended shelf life, and consistent quality across high-volume operations.

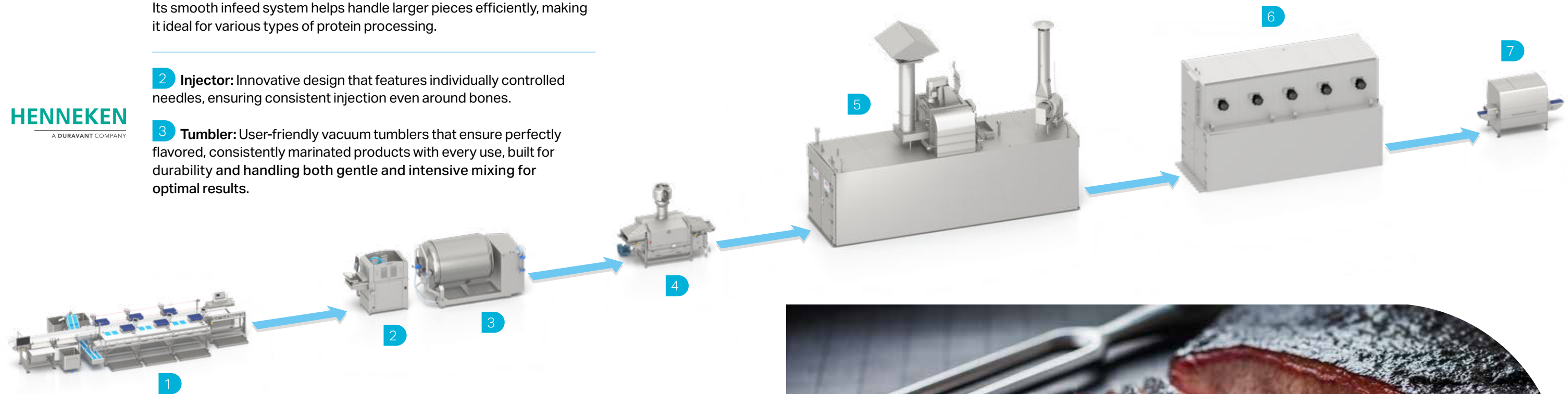

# PORK LOIN

Solutions that deliver unmatched versatility and flexibility while ensuring consistent results across any application.

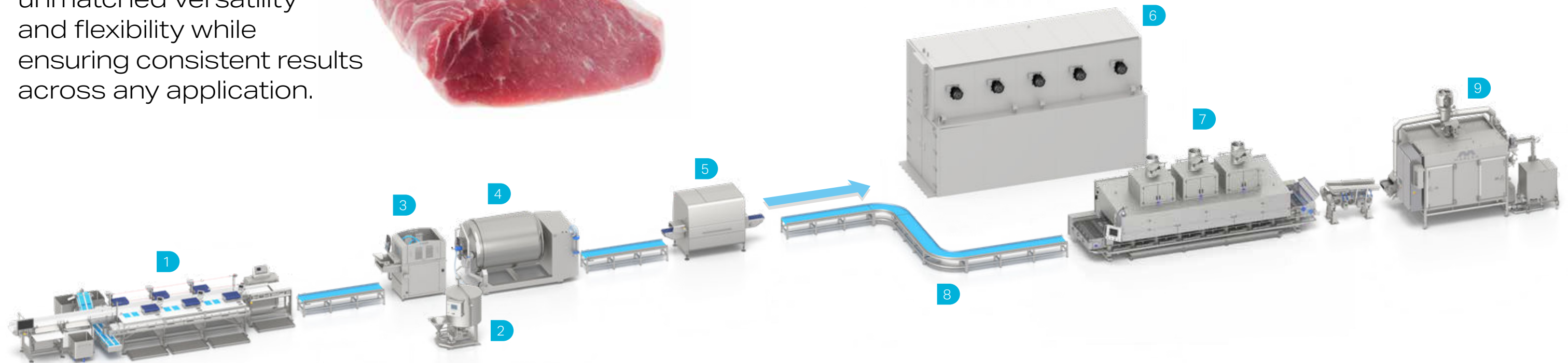

**1 Trim line:** An intelligent trimming system that tracks yield, capacity, and trim quality per operator. Real-time data throughout production enables quick adjustments and maximizes profitability.



**5 Portio:** A versatile portion cutter designed to create consistent, natural-looking portions. It uses advanced camera technology and adjustable cutting angles to improve product appearance and accuracy. Its smooth infeed system helps handle larger pieces efficiently, making it ideal for various types of protein processing.



**6 Blast Chill Cell:** Solutions that rapidly chill products with precise airflow and temperature control, ensuring food safety, extended shelf life, and consistent quality across high-volume operations.

**7 Infrared Grill:** Designed to ensure uniform surface coloring and precise roasting for consistent product quality and visual appeal.

**9 Spiral Oven:** Solutions that deliver unmatched flexibility with precise control for consistent results, uniform product quality, and cost-efficient performance across diverse applications.

**2 Brine Mixer:** Designed for precise blending and uniform consistency, ensuring optimal injection performance and reliable results across a wide range of applications.



**3 Injector:** Innovative design that features individually controlled needles, ensuring consistent injection even around bones.

**4 Tumbler:** User-friendly vacuum tumblers that ensure perfectly flavored, consistently marinated products with every use, built for durability and handling both gentle and intensive mixing for optimal results.



**8 Alignment Conveyor:** Precisely aligns and singulates products to maximize downstream equipment efficiency through customized, application-specific design.

**8 Transfer Conveyor:** Safe, efficient transfer of fresh and frozen products through a hygienic design available in smooth or rigidized stainless-steel construction for optimal food safety and cleanability.

# HAM

Solutions that combine flexibility for whole or portioned hams with advanced automation to streamline every step of the process.



**1 Trim line:** An intelligent trimming system that tracks yield, capacity, and trim quality per operator. Real-time data throughout production enables quick adjustments and maximizes profitability.

**2 Brine Mixer:** Designed for precise blending and uniform consistency, ensuring optimal injection performance and reliable results across a wide range of applications.



**3 Injector:** Innovative design that features individually controlled needles, ensuring consistent injection even around bones.

**4 Tumbler:** User-friendly vacuum tumblers that ensure perfectly flavored, consistently marinated products with every use, built for durability



## ADDITIONAL INTEGRATED LINE SOLUTIONS

**Bag Inserting:** Engineered to deliver perfectly formed and hygienically inserted bags with high-speed precision, supporting food safety, shelf-life protection, and efficient case-ready protein packaging for demanding production environments.

**Bag Sealing:** Designed to deliver airtight, contamination-preventing seals that enhance product freshness, extend shelf life, and ensure secure, leak-free protein packaging in high-throughput environments.

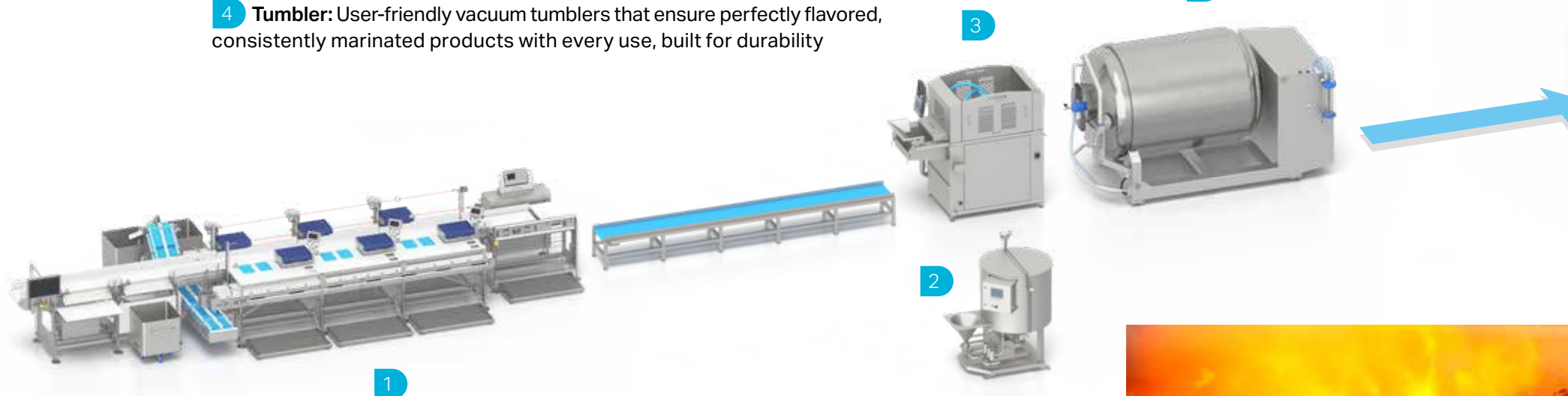
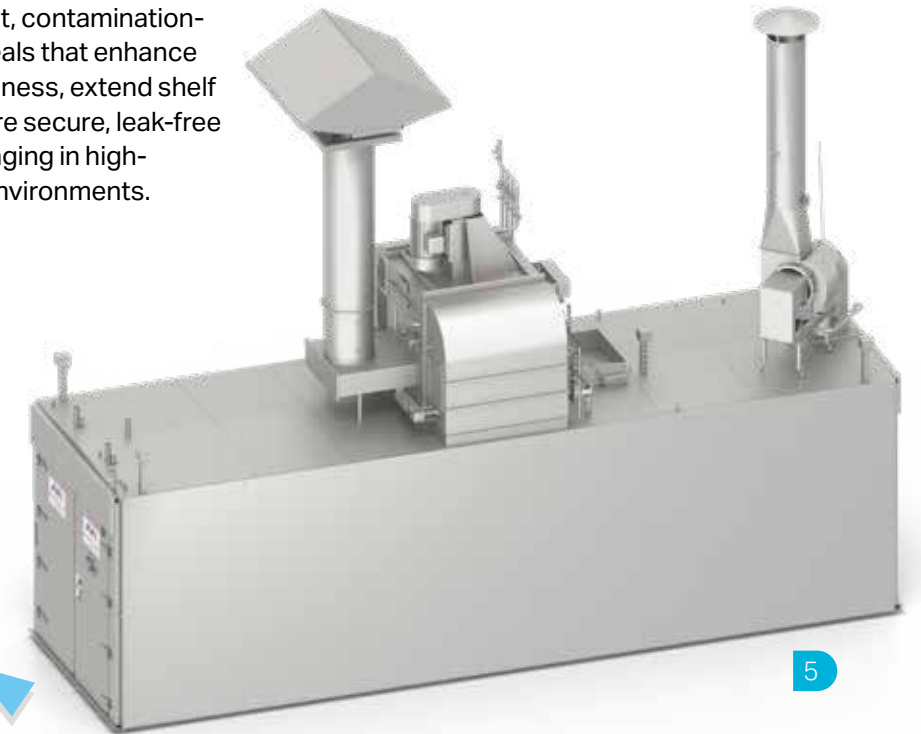

**5 Batch Oven:** Designed for precise, repeatable cooking with flexible configurations, ensuring consistent results, product integrity, and efficiency across a variety of applications.



# ADVANCED MEAT RECOVERY

Solutions that can mechanically separate all meat cuts from any cut-up or deboning equipment.

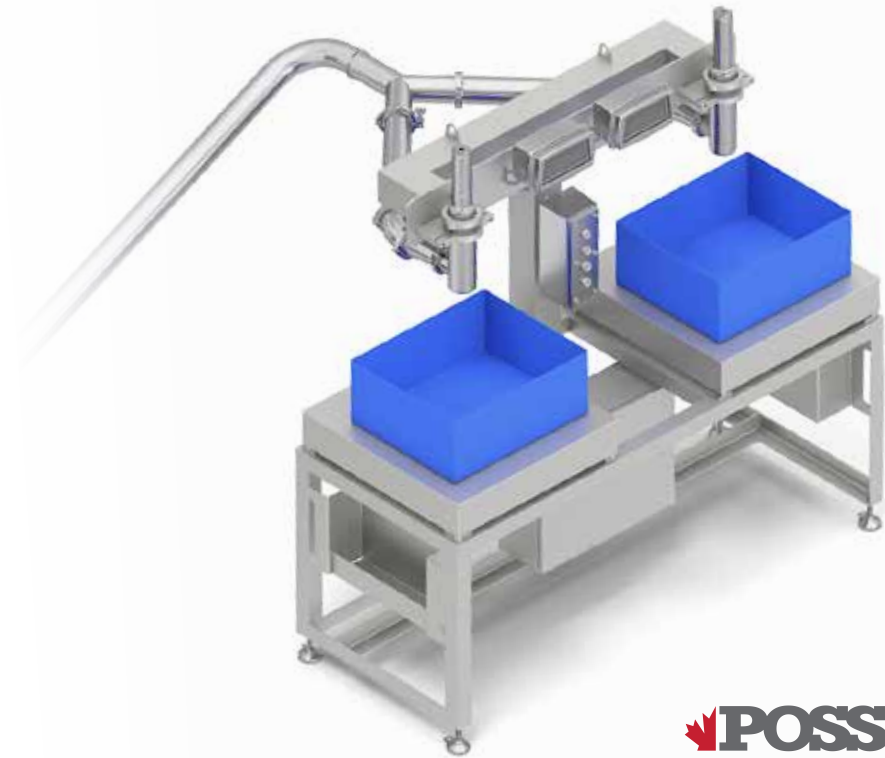

**1 Separator:** Meat separation systems available in compact, mid-, and high-capacity configurations for pork and beef applications. Designed for precise separation of meat, trim, and other raw materials to ensure consistent quality and yield. Optional features include customizable pumping and a dual box filling station for efficient handling.

# HAMBURGERS

Solutions that provide the highest consistency, accuracy and product integrity no matter the throughput.



- 9 Flame Grill:** Solutions designed to deliver authentic taste with premium searing, roasting, and grilling—ensuring consistent quality and product integrity.
- 3 Spiral Oven:** Solutions that deliver unmatched flexibility with precise control for consistent results, uniform product quality, and cost-efficient performance across diverse applications.



- 10 Alignment Conveyor:** Precisely aligns and singulates products to maximize downstream equipment efficiency through customized, application-specific design.
- 10 Transfer Conveyor:** Safe, efficient transfer of fresh and frozen products through a hygienic design available in smooth or rigidized stainless-steel construction for optimal food safety and cleanability.

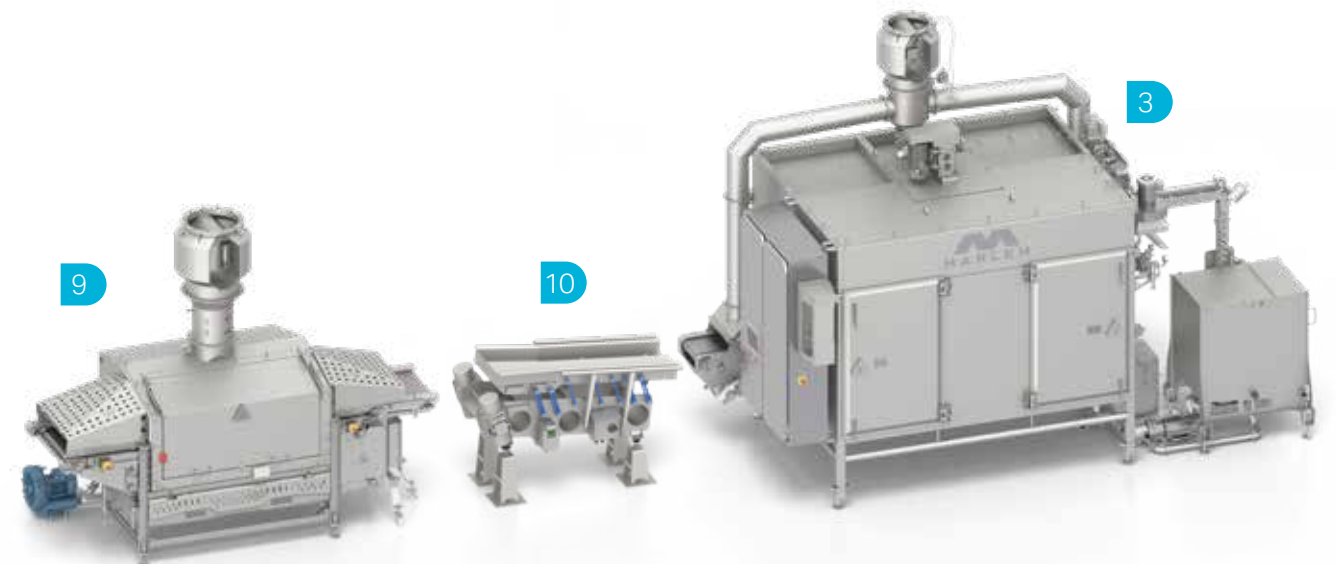

## Building Partnerships, Maximizing Value.

Duravent Lifecycle Services is the power behind our aftermarket solutions for Duravent's portfolio of food processing, packaging and material handling equipment. We bring a consultative approach to help you optimize the performance of your equipment throughout its entire service life. Our goal is to deliver service solutions that reduce operational disruptions and costs, optimize safety and quality, and improve the overall equipment effectiveness within your operation.

### SERVICES

	FIELD SERVICES		TECHNICAL SUPPORT		PREVENTIVE MAINTENANCE
	INSTALLATION & COMMISSIONING		APPLICATIONS SUPPORT		PRE-OWNED EQUIPMENT REGISTRATION

### PRODUCTIVITY

	TRAINING		SERVICE PLANS		PRODUCTIVITY PROGRAMS
	CUSTOMER CARE		UPGRADE & RETROFITS		PROJECT MANAGEMENT

### PARTS AND REPAIRS

	SPARE PARTS		ACCESSORIES & CONSUMABLES		REPAIR & REFURBISHMENT		PARTS KITS
---	-------------	---	---------------------------	---	------------------------	--	------------



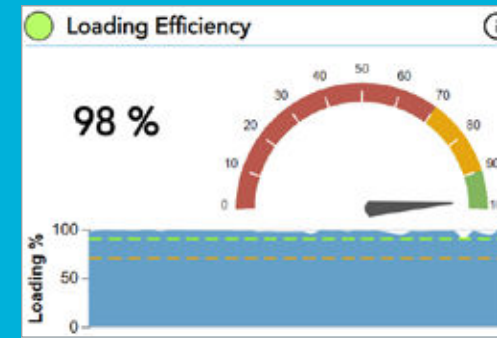

**Machine Efficiency**  
Increase yield by managing the key indicators



**Machine Maintenance**  
Reduce service costs through integrates tools and processes

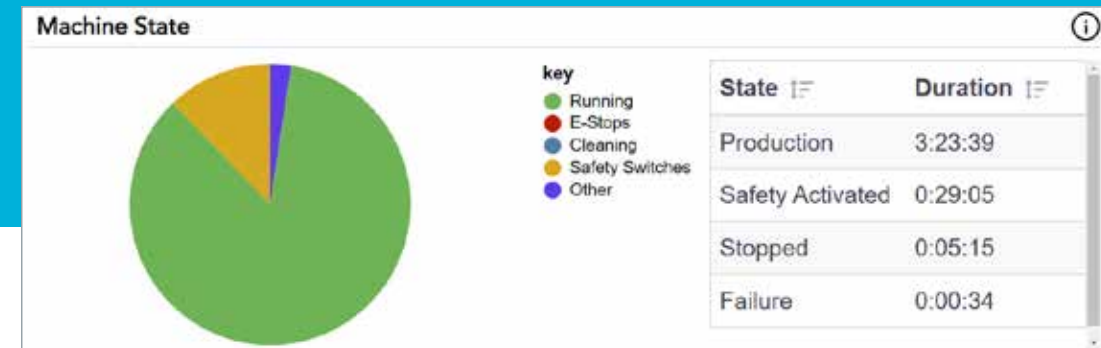

**Machine Health**  
Increase operational readiness with real time insights

## DIGITAL INTELLIGENCE

Duravant Lifecycle Services delivers comprehensive support to keep your equipment running at peak performance. Our solutions reduce downtime, improve safety, and extend equipment life—all with a consultative approach tailored to your operation.

Our IIoT services powered by Duravant ONSIGHT® provide processors with a wide range of benefits:

- **Machine Monitoring** – track all key indicators on the health and productivity of your equipment line
- **Maintenance Insights** – a one-stop shop for performing preventative maintenance, opening tickets, remote support, and tracking status
- **Measure Quality** – track the quality of your production
- **Real-time Alerts** – operator defined alerting on any signal that indicates a change in productivity or health of the machine
- **Reporting** – generate reports on key metrics that track fleet performance over time
- **Increase Safety** – indicators that ensure that the machine is being operated correctly
- **Customization** – data services that are custom fit to the operators' specific needs



- OEE Monitoring
- Machine Performance
- Machine Health
- Product Quality
- Maintenance



**MATRIX**

- Sales Orders
- Labelling
- Palletizing
- Inventory
- Traceability
- Yield Analysis

**KEEPING GOODNESS IN MOTION**

**WE ARE DURAVANT**



[DURAVANT.COM](https://www.duravant.com)



**TELEPHONE USA 844.DURAVANT**  
**TELEPHONE GLOBAL 1.630.635.3910**