

OPTI SERIES

VACUUM STUFFING
& PUMPING

SOLUTIONS

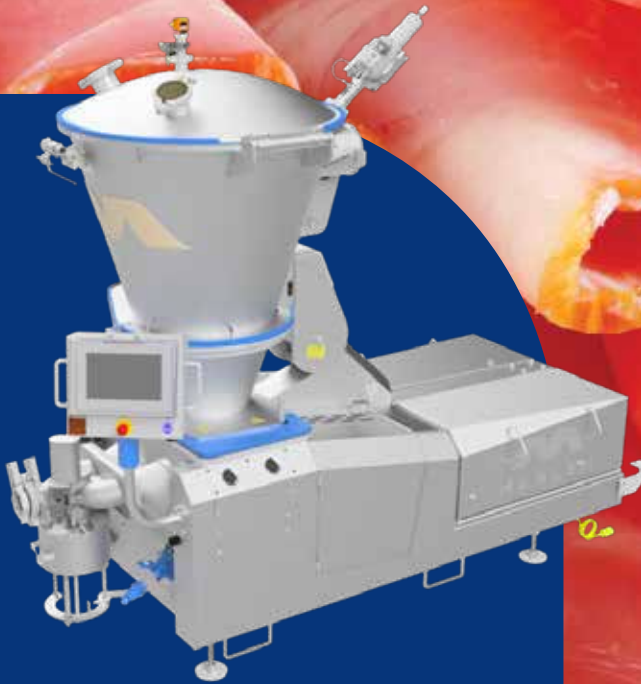
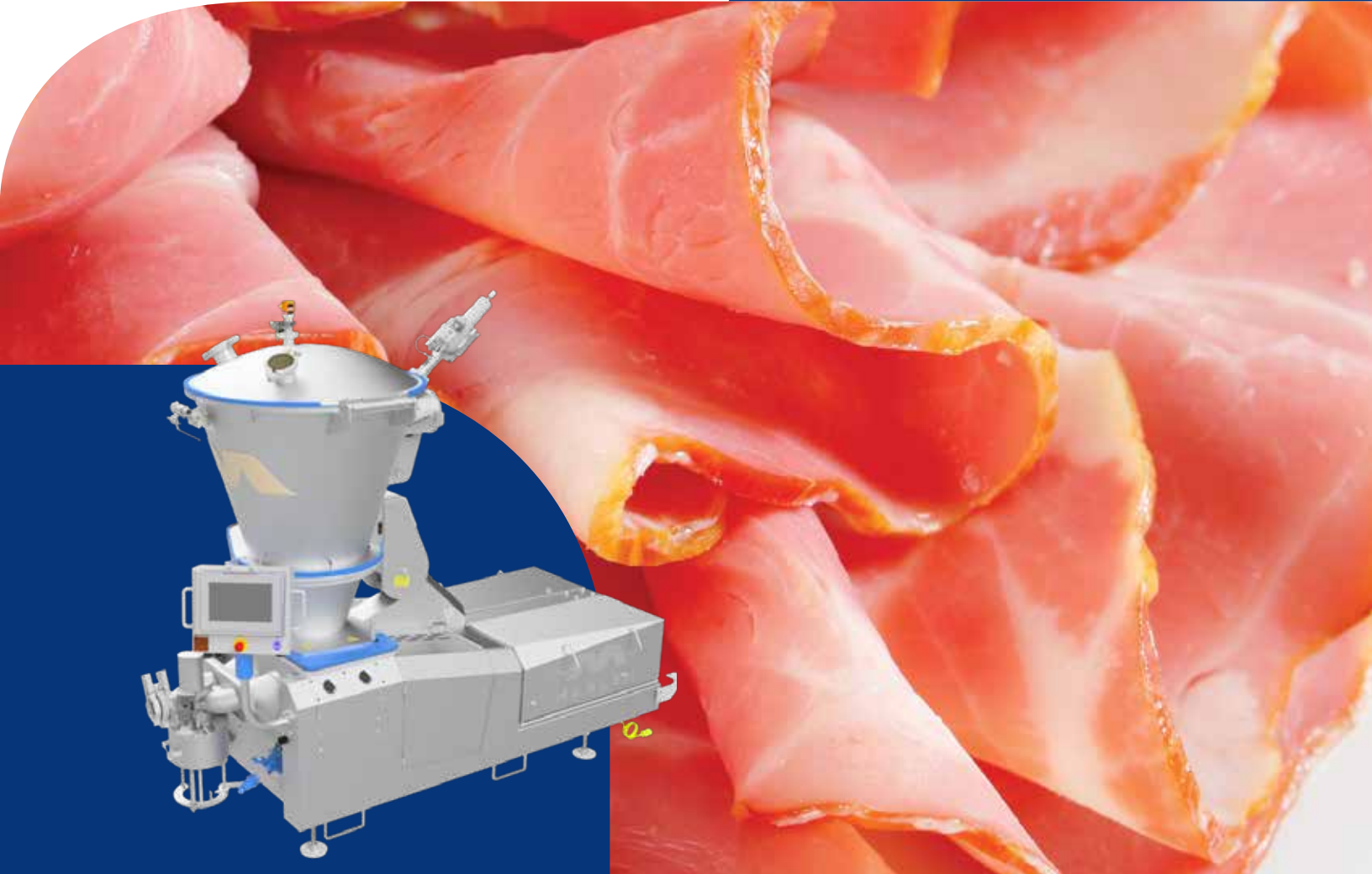

Continuous High Volume
Throughput. Optimal
Performance.



MARLEN

A DURAVANT COMPANY

OPTIMAL RESULTS

HIGHEST
YIELDS

TWIN PISTON VACUUM STUFFING & PUMPING

Our high volume Marlen Opti Series vacuum stuffing and pumping systems feature a twin-piston design for the most gentle handling, while providing optimal vacuumization for the most superior particle definition and highest product integrity. From whole muscle to sectioned, formed, and emulsified meat and poultry products to delicate ingredients included in soups and fillings, our Opti stuffers are trusted for producing premium products. All models can be equipped with a variety of hopper options designed to best suit application and product requirements.

FEATURES & BENEFITS

SUPERIOR PARTICLE DEFINITION AND PRODUCT INTEGRITY

With its product inlet valve measuring 8-9/16" in diameter, the Opti stuffing and pumping system allows product to be diffused across the pump's sheeting valve for the most gentle handling while maximizing vacuumization. This highly engineered design delivers premium whole muscle meats with the least amount of product damage. Producers of pepperoni, salami, mortadella and whole muscle meats rely on Opti pumps for best-in-class particle definition, product integrity and value.

OPTIMAL VACUUMIZATION

Marlen's patented twin-piston and sleeve design allows for maximum vacuumization throughout the system's hopper and pumping chamber. By exposing the product to optimal removal of entrapped air and achieving up to 29" of mercury, better weight control is achieved; shelf-life is extended and product density is increased, translating to measurable casing savings.

CONTINUOUS FLOW FOR PRECISE PORTIONING

Constant pressure and speed is maintained via Marlen's hydraulically-powered units, which maintain the same pressure while stopped as when in motion. The result: a precise metered flow for better weight control at the speeds required for high volume production environments.

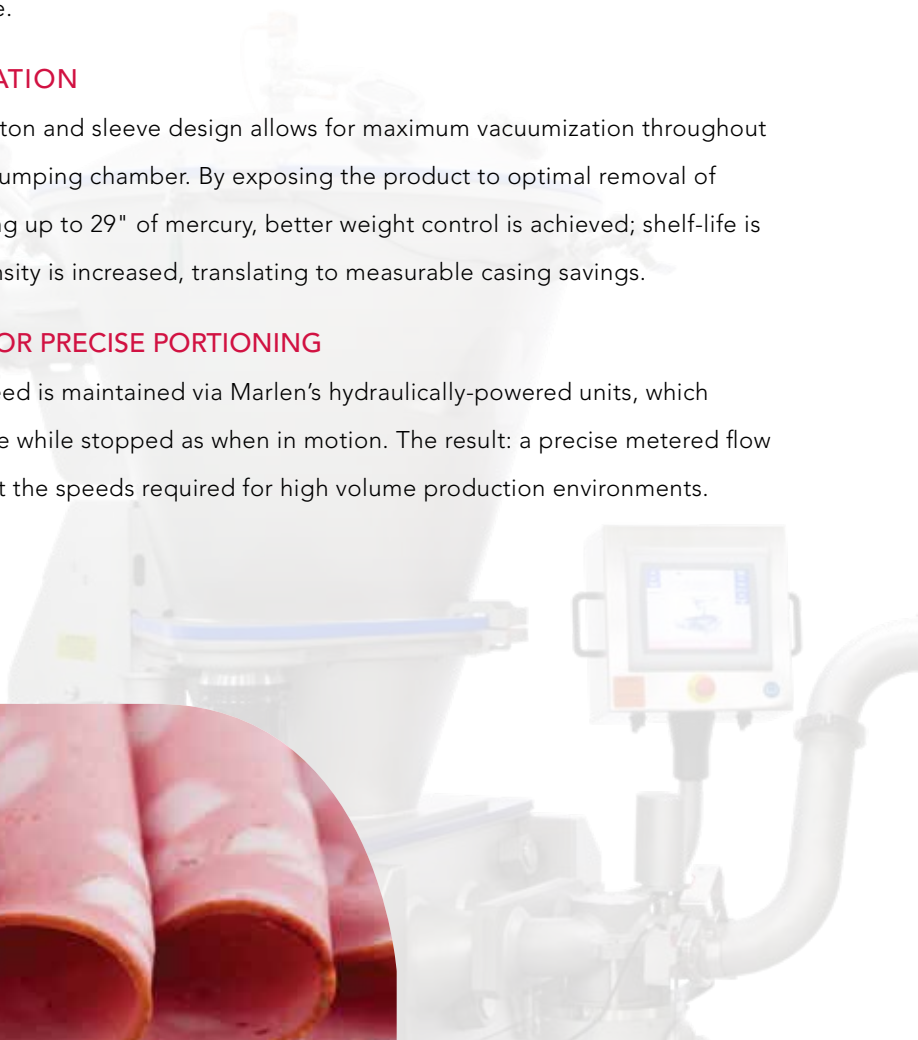
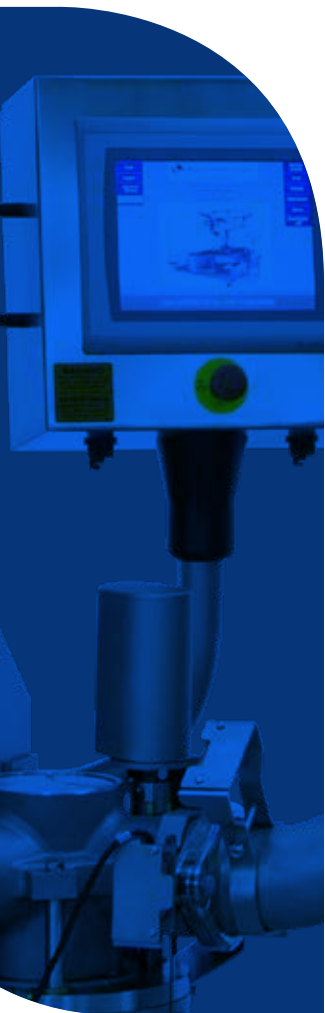

ADVANTAGES

A LOOK INSIDE OUR OPTI 280 MODEL

Optional Hopper Configurations

From open top hoppers to full vacuumizer hoppers with augers for load assist and complete versatility dependent upon application

State-of-the-Art Touch Panel Control

Easy to operate and control. Features diagnostic capabilities and large recipe storage capacity along with 8.4" touch screen.

Hydraulically-Driven Front Valve

Features positive shifting for continuous product flow

Twin-piston Pumping Chamber

Features a 10° incline that increases product flow into the pumping chamber. Easier loading into the pumping chamber ensures maximum operating efficiencies

Interior Lights

Helps visualize the sleeve area without opening doors.

Pre-assembled Manifolds

Precisely made and pretested, capable of withstanding the hydraulic pressure

Externally Adjustable Diffuser Valve

8" inlet enables the Opti series to maximize the product's exposure to vacuum

Stainless Steel Inlet Piping

Light and easy to assemble for improved sanitation.

Programmable Logic Controller (PLC)

Can be customized to meet your specific product needs

Rear Deck Doors

Lighter and sloped; includes updated seal to prevent leaks

Patented Dual Seal Electrical Box

Prevents water penetration into sensitive areas. Tested to 1350psi

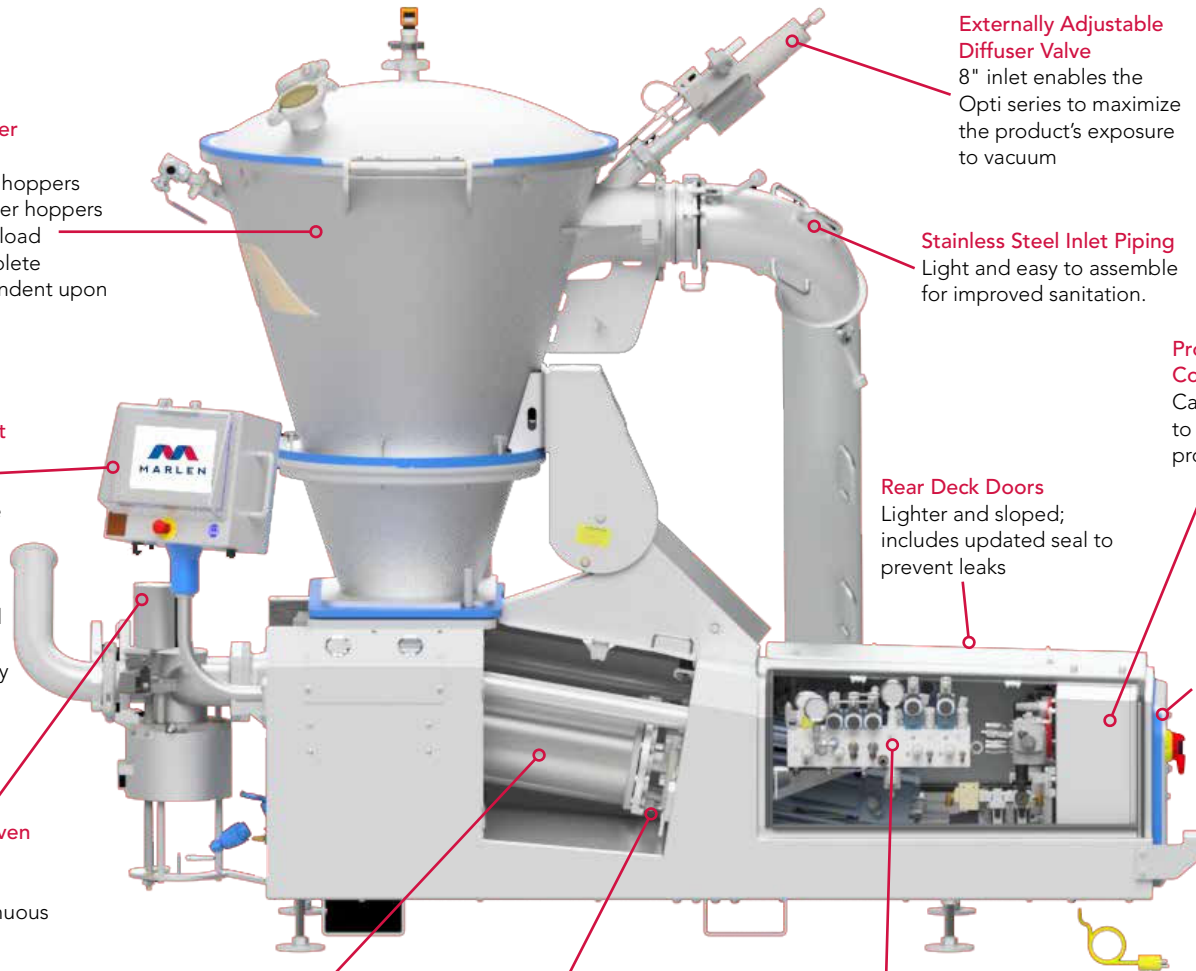

METHOD OF OPERATION

The Opti's twin-piston positive displacement pumping design is engineered for maximum versatility.

As the piston and sleeve retract, a perfect vacuum is created to facilitate loading of product into the pumping chamber. As product enters the sheeting valve, maximum surface area is exposed. This feature along with auger assist allows the pump to utilize full vacuum in the hopper, resulting in the highest vacuumization possible.

Finally, continuous stuffing and pumping action without pulsation and precise metering allow the Opti to maintain constant pressure and speeds for a continuous product flow.

With pumping capacities up to 28,000 pounds per hour, a variety of hopper options, and a host of complementary equipment such as inline grinders, transfer valves, portioners and depositors, the Opti series features a wide range of models for ultimate versatility and an endless array of applications.



HOPPER STYLES

One-Piece Auger Hopper

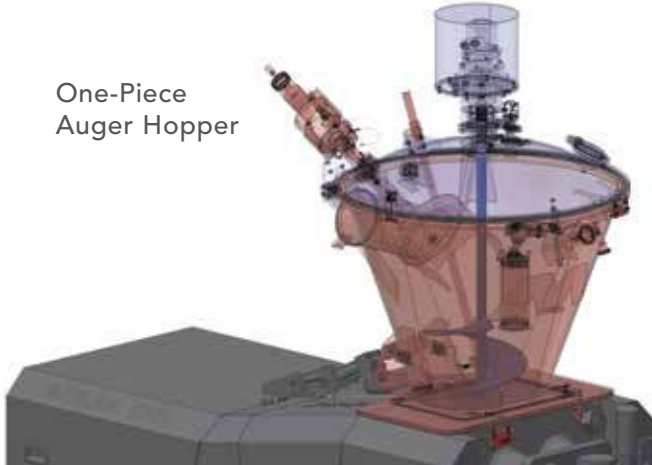

Vacuumizer Combo Hopper*



**Available in four sizes from 1,000-2,500-lb. capacities*

One-Piece Open Top Auger Hopper

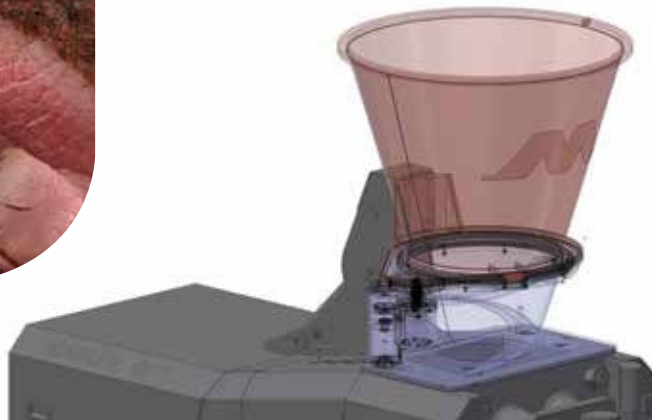

Two-Piece Auger Hopper



AUXILIARY EQUIPMENT

COV Portioner



RS Portioner



Hydraulic Fluid Cooling Unit



Electric Vari-Kut In-line Grinder

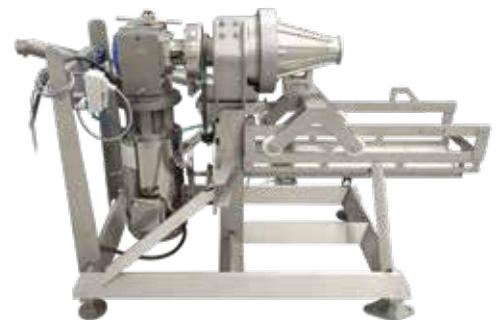

TECHNICAL SPECIFICATIONS

Model	Piston Diameter	Piston Stroke	Maximum (wt.) Capacity	Maximum Volume	Product Outlet	Max Product Pressure	Machine Weight
Opti 100	7-1/8" 181 mm	14" 355 mm	10,000 lbs/hr 4,536 kg/hr	20.0 gpm 76 lpm	4" 102 mm	250 psi 17 BAR	2,300 lbs 1,043 kg
Opti 120 HP	6-1/2" 166 mm	10" 250 mm	12,000 lbs/hr 5,443 kg/hr	22.7 gpm 86 lpm	4" 102 mm	500 psi 34 BAR	3,400 lbs 1,542 kg
Opti 200 Inboard	8-9/16" 217 mm	14" 355 mm	20,000 lbs/hr 9,071 kg/hr	37.8 gpm 143 lpm	4" 102 mm	250 psi 17 BAR	4,270 lbs 1,937 kg
Opti 200 Outboard	8-9/16" 217 mm	10" 250 mm	20,000 lbs/hr 9,071 kg/hr	37.8 gpm 143 lpm	4" 102 mm	250 psi 17 BAR	3,400 lbs 1,542 kg
Opti 280	8-9/16" 217 mm	14" 355 mm	28,000 lbs/hr 12,701 kg/hr	55 gpm 208 lpm	4" 102 mm	430 psi 29 BAR	4,000 lbs 1,815 kg
Opti 340	8-9/16" 217 mm	14" 355 mm	34,000 lbs/hr 15,421 kg/hr	66 gpm 250 lpm	4" 102 mm	250 psi 17 BAR	4,000 lbs 1,815 kg

TECHNICAL DRAWINGS

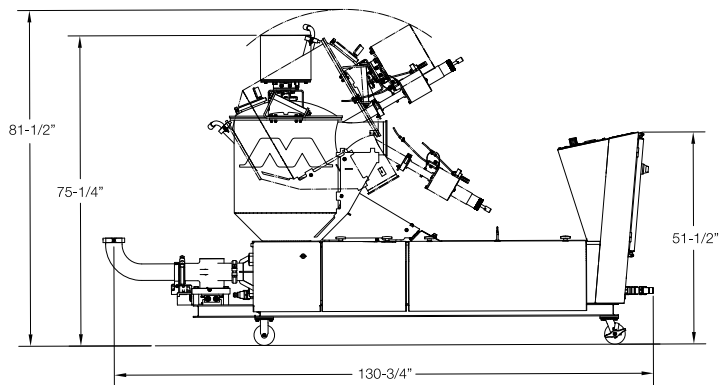

OPTI 100

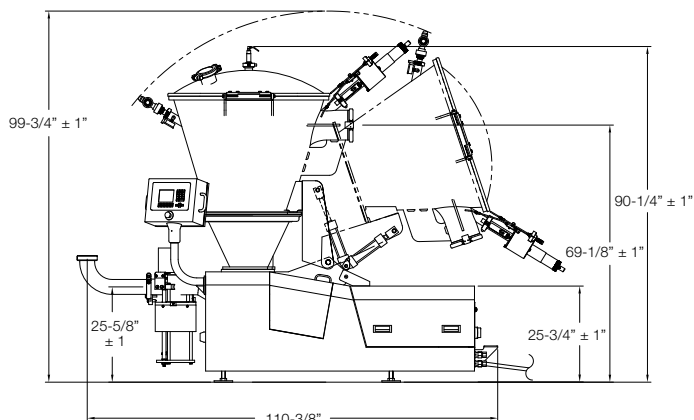

OPTI 120 HP/200 Outboard

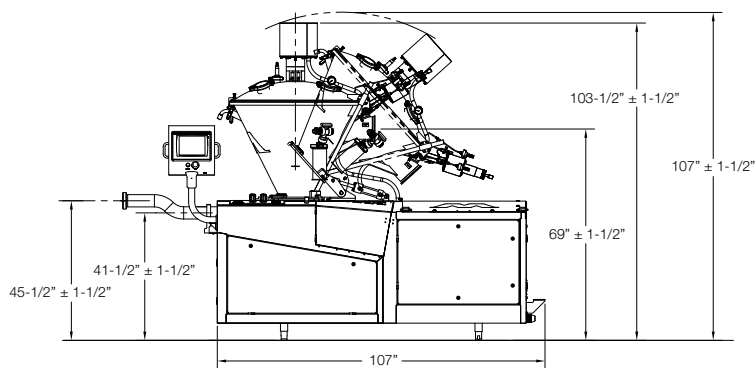

OPTI 200 Inboard

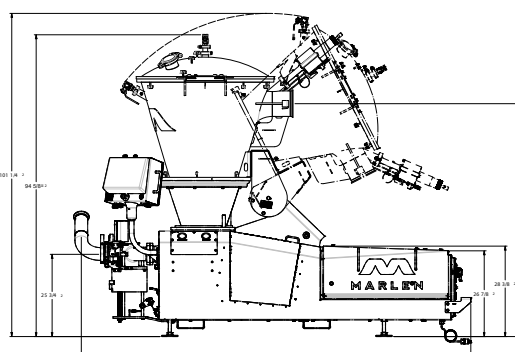

OPTI 280-340

ADVANTAGES

HIGH VOLUME, CONTINUOUS VACUUM STUFFING AND PUMPING SYSTEMS

From twin-piston pumps and stuffing systems to extruders, transducer portioning systems, depositors, forming systems and volumetric portioners, Marlen's stuffers and portioners assure value through the highest consistency, accuracy, and product integrity.

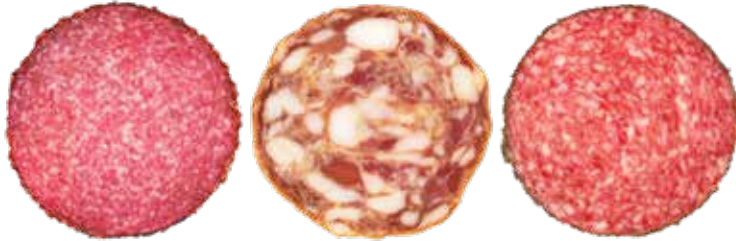

MARLEN

A DURAVANT COMPANY

4780 NW 41ST ST, STE. 100 • RIVERSIDE, MO 64150

TEL 913.888.3333 | TOLL FREE 800.862.7536 | FAX 913.888.6440 | EMAIL: SALES@MARLEN.COM | WWW.MARLEN.COM



MARLEN IS A MEMBER OF THE DURAVANT FAMILY OF COMPANIES

FOOD SORTING & HANDLING | PROTEIN PROCESSING | PACKAGING | MATERIAL HANDLING

www.duravant.com