

Flame Peeler: 60"

Our Afoheat™ Flame Peelers use gas-powered direct flame technology to gently roast, char, peel and pasteurize as needed, with minimal yield loss. Flame Peelers are intended for produce applications such as roasting bell peppers, charring tomatillos, peeling onions, and more.

The 60" Flame Peeler is designed for processors with high capacity requirements depending on application and product size throughputs can range drastically from 5,000-28,000 lbs (2,200-12,700 kg) / hr.

Benefits/Features:

- Direct flame completely envelops the product to gently peel, roast, and char
- 24 independently controlled burners allow for complete control of color development across the belt
- Small footprint, comparatively large throughput
- Flexibility across product applications to roast, peel, char, and pasteurize
- Easy to use HMI screen allows for recipe creation for consistent results, every time
- Built to USDA accepted sanitary design standards
- CE compliant

Our Flame Peelers are designed to offer an alternative to rotary drum roasters to improve processing times and yields. Unlike traditional tumbling methods, the Flame Peeler gently conveys the product through multiple adjustable ribbon burners to ensure product integrity, offering improved yields and product quality. Our unique heat shield design intensifies heat in the product zone, maximizing capacity and minimizing energy use.

Individual burners can be set "on" or "off" and adjustments can be made to flame angle, intensity, and distance from the product, to meet

exact specifications. Users also have complete control over belt speeds, or residence times, to dial in targeted roasting profiles, typical residence times vary from 20-60 seconds.

This patented process for flame peeling onions provides a 5 log reduction in *Listeria innocua*. Rather than using traditional methods of "top" and "tailing" onions, this method uses flame to burn off the outer thin layers without damaging the meaty layers, resulting in approximately 3% yield loss. The result, a surface pasteurized product with minimal yield loss.



Afoheat™ Flame Peeler 60"



Product Specifications:

Model	Belt Width	Burners	Capacity Range	Machine Length	Machine Width	Machine Height	Machine Weight
60"	60" 1500 mm	24	5,000 – 28,000 lbs/hr 2,200 – 12,700 kg/hr	20.17' 6.15 m	8.67' 2.64 m	8.17' 2.49 m	10,000 lbs 4,535 kg

Utility Specifications:

Model	Electrical Power Utilities	Gas Utilities	Drains	Extraction	Cleaning Water
60"	USA: 480 VAC, 3 Ph, 42 Amp, 60 Hz EUR: 380 VAC, 3 Ph, 53 Amp, 50 Hz AUS: 415 VAC, 3 Ph, 48 Amp, 50 Hz	Up to 5.0 MBTU/Hr at 2 PSI (7 PSI max); 2" (50 mm) NPT	Overflow – 3" (75 mm) Sanitary	2 x 28" (2 x 711 mm) Outlet; Up to 14,000 CFM (396 m³/min) Total	1/2" (12 mm) NPT inlet; Up to 60 GPH (227 liter/hr)

Accessories:

- Charcoal trays
- Steam impingement manifolds
- Discharge roller bar to prevent products from sticking to the belt
- Rod, wire, or mesh belt
- Infeed or outfeed belt extension



Technical Diagram:

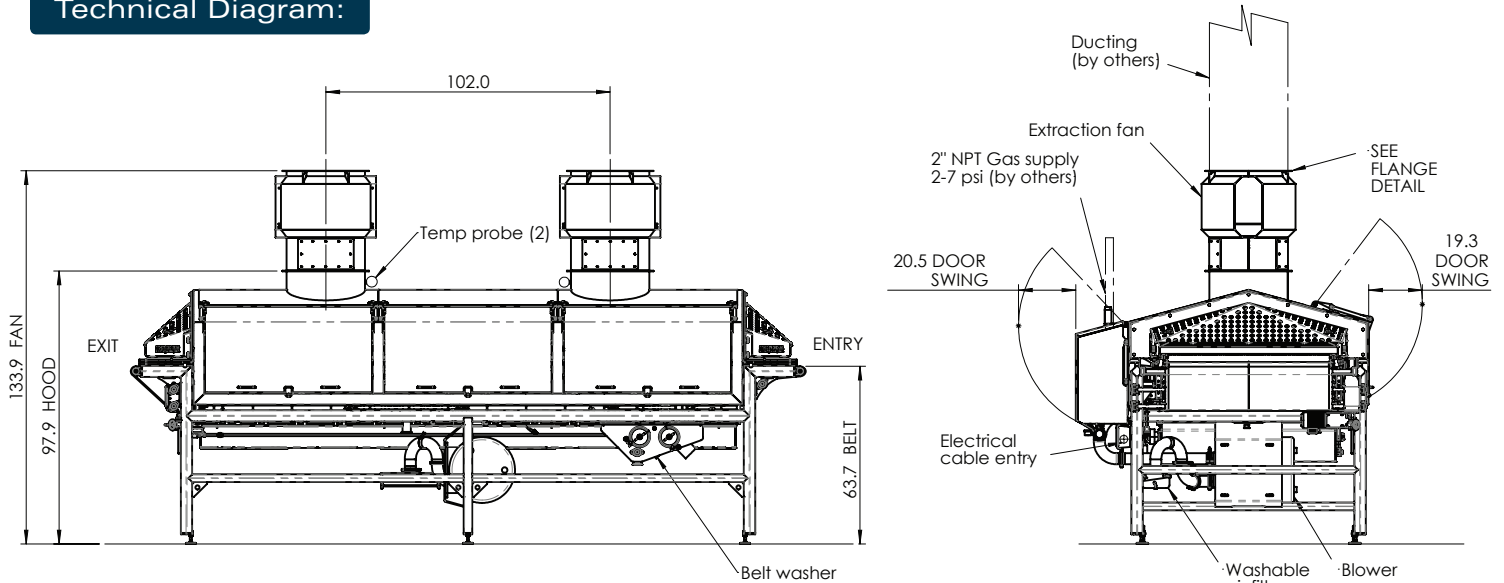

4780 NW 41st St, Ste. 100 • Riverside, MO 64150

Tel 913.888.3333 | Toll Free 800.862.7536 | Fax 913.888.6440 | email: sales@marlen.com | www.marlen.com



MARLEN INTERNATIONAL IS A MEMBER OF THE DURAVANT FAMILY OF COMPANIES

www.duravant.com

PACKAGING SOLUTIONS | FOOD PROCESSING SOLUTIONS | MATERIAL HANDLING SOLUTIONS | SUPPORTPRO