

# Tunnel of Fire – Mini

**Our Afoheat™ Tunnel of Fire offers natural roasting and browning benefits** with gas-powered direct flame technology for whole birds, deli loaves, or large proteins. Multiple ring-shaped ribbon burners ensure equal and complete exposure to the product on all sides, for rapid natural braised coloring with minimal weight loss.

Depending on product application and process integration the Tunnel of Fire will sear, grill, roast, braise, brown, and surface pasteurize product.

The Mini Tunnel of Fire is designed for processors with capacity requirements of 4 to 15 pieces per minute, and is often installed to replace hand-charring or as a pasteurization step.

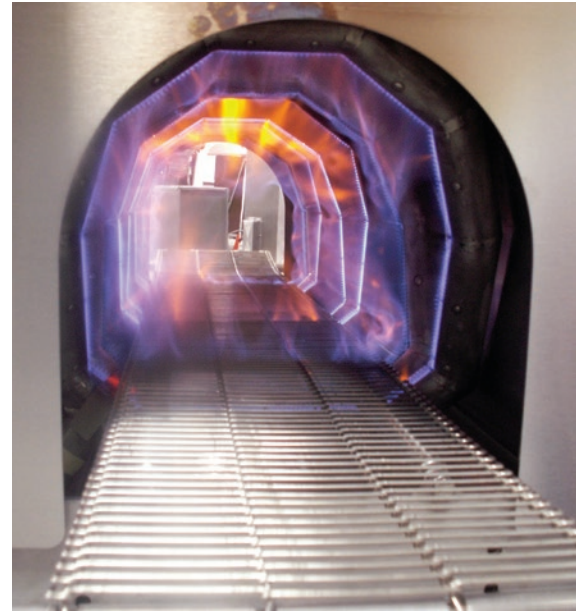

Afoheat™ Tunnel of Fire - Mini

## Benefits/Features:

- Direct flame encircles product in a 360° tunnel
- Natural browning effects and surface pasteurization in less than one minute
- Coloring mimics hand charring and blow torching effects or rotisserie results
- Small footprint, comparatively large throughput
- Achieves a 3-log reduction in *Listeria Monocytogenes* (when integrated post cook and chill)
- Can be used as a standalone unit for simple surface pasteurization or integrated with a cook line to seal in juices
- Easy to use HMI screen allows for recipe creation for consistent results, every time
- Built to USDA accepted sanitary design standards
- CE compliant

Our Tunnel of Fire is ideally integrated after the product is already cooked and chilled to 2-4°C (35-39°F). The Tunnel then serves to naturally color the product through direct flame, while simultaneously achieving surface pasteurization. Most products achieve the desired coloring effects with residence times of 30-60 seconds. In this time typically only 2-5 mm of the product surface is

affected by the heat, the product then rapidly cools, allowing for in line packaging. If proper handling measures are taken, the surface pasteurized product improves shelf life up to 30%.

When integrated prior to cooking, much like our Flame Grill series, the Tunnel of Fire effectively sears product and rapidly enhances color and flavor with minimal yield loss.



## Product Specifications:

Model	Belt Width	Capacity Range	Machine Length	Machine Width	Machine Height	Machine Weight
Mini	11" 280 mm	4 – 15 pieces / minute	6.06' 1.85 m	3.82' 1.16 m	6.83' 2.08 m	750 lbs 340 kg

## Utility Specifications:

Model	Electrical Power Utilities	Gas Utilities	Water	Drains	Combustion Air	Extraction Exhaust
Mini	USA: 240 VAC, 1 Ph, 30 Amp, 60 Hz EUR: 220 VAC, 1 Ph, 30 Amp, 50 Hz AUS: 220 VAC, 1 Ph, 30 Amp, 50 Hz	840,000 BTU@ 2-7 PSI, 13.3 CFM (22.1 m <sup>3</sup> /hr) 1" (25 mm) NPT	90 GPH, 1" (25 mm) Sanitary	2.5" (75 mm) Sanitary	130 CFM at 1.5 PSI; 1.5" NPT	4000 CFM 15" I.D.

## Accessories:

- Discharge roller bar to prevent products from sticking to the belt
- Rod, wire, or mesh belt
- Infeed or outfeed belt extension



## Technical Diagram:

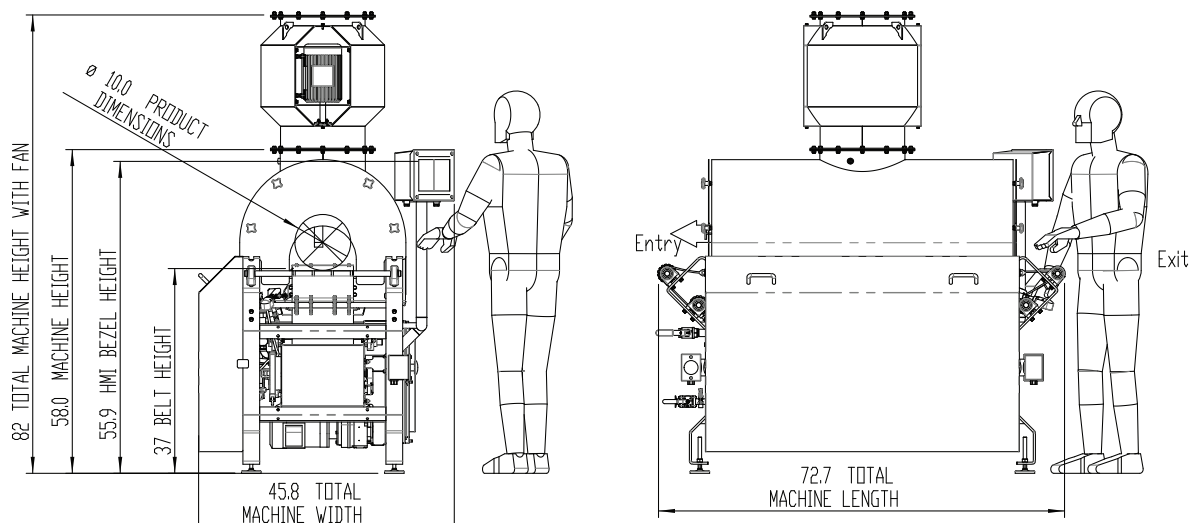

4780 NW 41st St, Ste. 100 • Riverside, MO 64150

Tel 913.888.3333 | Toll Free 800.862.7536 | Fax 913.888.6440 | email: sales@marlen.com | www.marlen.com



MARLEN INTERNATIONAL IS A MEMBER OF THE DURAVANT FAMILY OF COMPANIES

PACKAGING SOLUTIONS | FOOD PROCESSING SOLUTIONS | MATERIAL HANDLING SOLUTIONS | SUPPORTPRO

[www.duravant.com](http://www.duravant.com)