

OPTI 100 Vacuum Stuffing & Pumping System

Our Marlen Opti Series stuffing and pumping systems feature twin-piston pumps for the gentlest handling while providing optimal vacuumization for the most superior particle definition and highest product integrity. From whole muscle to sectioned, formed and emulsified meat and poultry products to sliced peaches, diced tomatoes and lobster filled ravioli, our Opti stuffers and pumps can be equipped with a variety of hopper options designed to match application and product requirements.



Benefits/Features:

- Simplicity; no digital controls
- All the basics of a twin piston Marlen pump at a fraction of the cost
- Small footprint and easily portable
- Proven twin-piston design
- Largest product openings
- Zero-slip design eliminates product degradation
- Minimal product damage and fewer cuts
- Designed to eliminate the need for downstream accumulators or bypass
- Precise metered flow or constant pressure control
- Built to USDA accepted standards
- Smaller number of parts simplifies cleanup



Maximum removal of entrapped air. One-Piece Vacuumizer Hopper with auger for load assist. Marlen's unique high-differential vacuum ensures maximum removal of entrapped air resulting in denser product, more accurate portion control, and longer shelf life.

Accurate portioning. Patented, Hydraulically-driven Front Valve delivers positive shifting for continuous, even product flow, and more accurate portion weight control.

Gentler on product. Twin Piston Pumping System designed to gently deliver products to down-stream processes. The zero-slip design maintains product integrity for products ranging from the highly abrasive to whole muscle. The system is gentle on your products and reduces wear on the unit, extending its life.

Compact Design. Accommodates limited spaces and heavy-duty casters provide easier portability.



MARLEN

MARLEN. REAL. SMART.



Product Specifications:

Model	Piston Diameter	Piston Stroke	Maximum (wt.) Capacity	Maximum Volume	Product Outlet	Max Product Pressure	Machine Weight
Opti 100	7-1/8" 181 mm	14" 355 mm	10,000 lbs/hr 4,536 kg/hr	20.0 gpm 76 lpm	4" 102 mm	250 psi 17 BAR	2,300 lbs 1,043 kg

Utility Specifications:

Model	Pump Utilities	Air Requirements	Power Unit Utilities	Cooling Water	Vacuum Pump
Opti 100	110 V 10 Amp (single phase)	3 CFM at 100psi	25 hp, 230/460 V (3 Ph/60Hz 68/34 Amp)	Up to 8 gpm	5 hp, 230/460 V (7.6 Amp)

Technical Diagram:

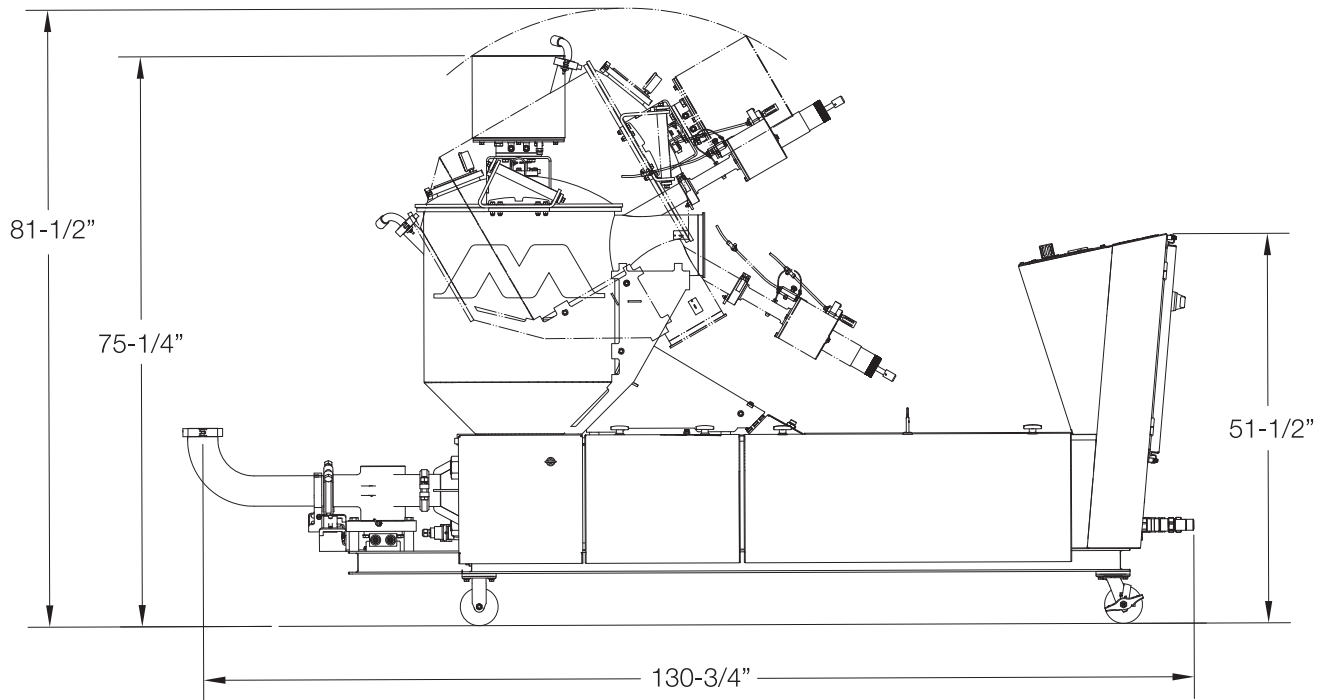

MARLEN



MARLEN INTERNATIONAL

A DURAVANT COMPANY

4780 NW 41st St, Ste. 100 • Riverside, MO 64150

Tel 913.888.3333 | Toll Free 800.862.7536 | Fax 913.888.6440 | email: sales@marlen.com | www.marlen.com



THE DURAVANT FAMILY OF COMPANIES

MARLEN INTERNATIONAL | FISCHBEIN | HAMER | MESPACK | FMH CONVEYORS

www.duravant.com